

An aerial photograph of a river with white water rapids. The water is a mix of green and blue, with white foam from the rapids. On the right side, there are several bright blue, wavy, energy-like streaks that appear to be overlaid on the image. The overall scene is dynamic and energetic.

CfD Application Guidance

Guidance by the EMR Delivery Body for Allocation Round 5
Final Version - March 2023

Legal Disclaimer and Copyright



Disclaimer

This guidance document has been prepared by National Grid Electricity System Operator Limited (NGESO) and is provided voluntarily and without charge. Whilst NGESO has taken all reasonable care in preparing this document, no representation or warranty either expressed or implied is made as to the accuracy or completeness of the information that it contains and parties using information within the document should make their own enquiries as to its accuracy and suitability for the purpose for which they use it. Neither NGESO nor any other companies in the National Grid plc group, nor any directors or employees of any such company shall be liable for any error or misstatement or opinion on which the recipient of this document relies or seeks to rely other than fraudulent misstatement or fraudulent misrepresentation and does not accept any responsibility for any use which is made of the information or the document or (to the extent permitted by law) for any damages or losses incurred.

Capitalised terms used in this document shall have the same meanings given in the Contracts for Difference (Allocation) Regulations 2014 (as amended).

Please note that the rules outlined in the Allocation Framework for AR5 and Contracts for Difference (Allocation) Regulations 2014 (as amended) take precedence over this guidance document and participants are encouraged to familiarise themselves with these rules and regulations, and if appropriate seek legal advice, before proceeding with an application.

Confidentiality

This guidance document, and its contents should be considered as confidential in nature, and this document is supplied on this basis. No part of this document may be reproduced in any material form (including photocopying and restoring in any medium or electronic means and whether or not transiently or incidentally) without the written permission of NGESO.

Copyright National Grid 2023, all rights reserved.

Version Control



The table below will record the page numbers of any new changes to the document for each version. New general changes are highlighted in yellow throughout the guidance document. Any changes updated due to policy changes are highlighted in blue.

#	Changes	Pages	Date
1.0	Original draft for customer comment	-	01/11/2021
1.1	Final Version	-	25/11/2021
1.3	Page Numbers added, removal of navigation bar.	-	20/05/2022
2.0	Draft version for Allocation Round 5	-	
	• General document formatting changes	110, 126	
	• Requirements for Floating Offshore Wind Supply Chain Plan Statements	108	06/02/2023
	• Addition of Private Wire Contract selection and subsequent declarations	11	
	• Addition of the eligible technologies and applicable delivery years	39	
	• Clarification that Solar PV capacity must be entered as the MWAC capacity	134	
2.1	Final Version for Allocation Round 5	4, 141	
	• Updated the logo for the Department for Energy Security and Net Zero	15, 127	22/03/2023
	• Updated information on when Applications can be withdrawn in the Allocation process	134	
	• Updated definition for Target Commissioning Date in-line with Allocation Framework Schedule 1	136	
	• Updated that the Non-Qualification Review window for the Delivery Body is now 10 working days	122	
	• Updated links to the Remote Island Wind gov.uk support documents		

Introduction



- National Grid Electricity System Operator Limited (NG ESO) is the Delivery Body for Electricity Market Reform (EMR). Part of this role includes administering the qualification process and running the allocation of Contracts for Difference (CfD), in accordance with the CfD legislative framework and **Department for Energy Security and Net Zero (ESNZ)** documents, specific to each CfD Allocation round.
- This document is part of a suite of guidance documents prepared by NG ESO which is to be used in conjunction with the relevant [Allocation Framework](#). It is designed to assist you with the technical aspects of completing the application form and the subsequent allocation processes.
- There is a feedback form attached to this document (in the top right-hand corner of this document). Please use the feedback form to provide feedback on this guidance document.
- This guidance document outlines the pre-application activities that Applicants are required to complete, prior to submitting a full application. However, you will still need to familiarise yourself with the [Allocation Framework](#) and eligibility requirements of the scheme when applying for a CfD, as this guidance is a supplementary document and is not an exhaustive list of the rules and eligibility requirements.
- A general overview of the CfD mechanism and Delivery Partners can be found [here](#) on our combined website.
- The Contracts for Difference Delivery Partners are:



Department for
Energy Security
& Net Zero



For general enquiries or support in using this guidance, please contact us via:

Phone: 01926 655 300

Email: EMR.CfD@nationalgrideso.com

How to use this guide



This guidance document provides Applicants with simple and transparent step-by-step instructions on how to create an Application(s) in the EMR DB Portal in order to participate in the 2023 Contracts for Difference Allocation Round.

Before creating an Application in the EMR DB Portal, you must first have registered a company. Refer to the CfD Registration guidance and user management guidance for instructions on how to do this.

Further guidance is also available on the EMR website by clicking on the guidance link boxes throughout this document. You do not need to sign into the EMR DB Portal to view the guidance documents.

Click on the home icon to return to the contents page.



We welcome all feedback so click on the feedback icon to leave any comments you may have regarding this guidance document. It can be found at the end of the document [here](#).



Example Guidance Box

Round 5

Contracts for Difference Document Library

✓	📄 Name	Modified
▶	Category : Allocation Round 5 Guidance Document (2)	
▶	Category : Allocation Round 5 Guidance Video (1)	
▶	Category : Supporting Information (1)	

For general enquiries or support in using this guidance, please contact us via:

Phone: 01926 655 300

Email: EMR.CfD@nationalgrideso.com

Contents (1/2)



1.0 [Completing the Application Form](#)

1.1 [Application overview and demonstration](#)

1.2 [Application Form - System view](#)

1.3 [Application Form Checklist](#)

1.4 [Application - Additional Technology Information](#)

1.5 [Application next steps](#)

2.0 [Qualification](#)

2.1 [Key Qualification Criteria](#)

Contents (2/2)



3.0 [Reviews](#)

3.1 [Non-qualification Review process overview](#)

3.2 [Non-qualification Review requirements](#)

4.0 [Appeals](#)

4.1 [Appeals process](#)

4.2 [Pending \(Allocation during Appeals\)](#)

5.0 [Contact Us](#)



1.0 Completing the Application Form



This section contains information on how to create your Application in the EMR DB Portal.

- 1.1 - 1.3 covers the Application requirements, applicable to all Technology Types.
- 1.4 covers information that is specific to certain technology types.
- 1.5 covers the next steps of the Application process, once the Application Window has closed.

It should be used in conjunction with the **Pre-Application Activities Guidance document** and **Section 2.0 (Qualification)** of this guidance document.

Select from the buttons opposite to find out more.

1.1 Application overview & demonstration

1.2 Application (generic) – system view

1.3 Application (generic) checklist

1.4 Application – Additional Technology Information

1.5 Application next steps

1.0 Completing the Application Form



Delivery Body Portal System Requirements

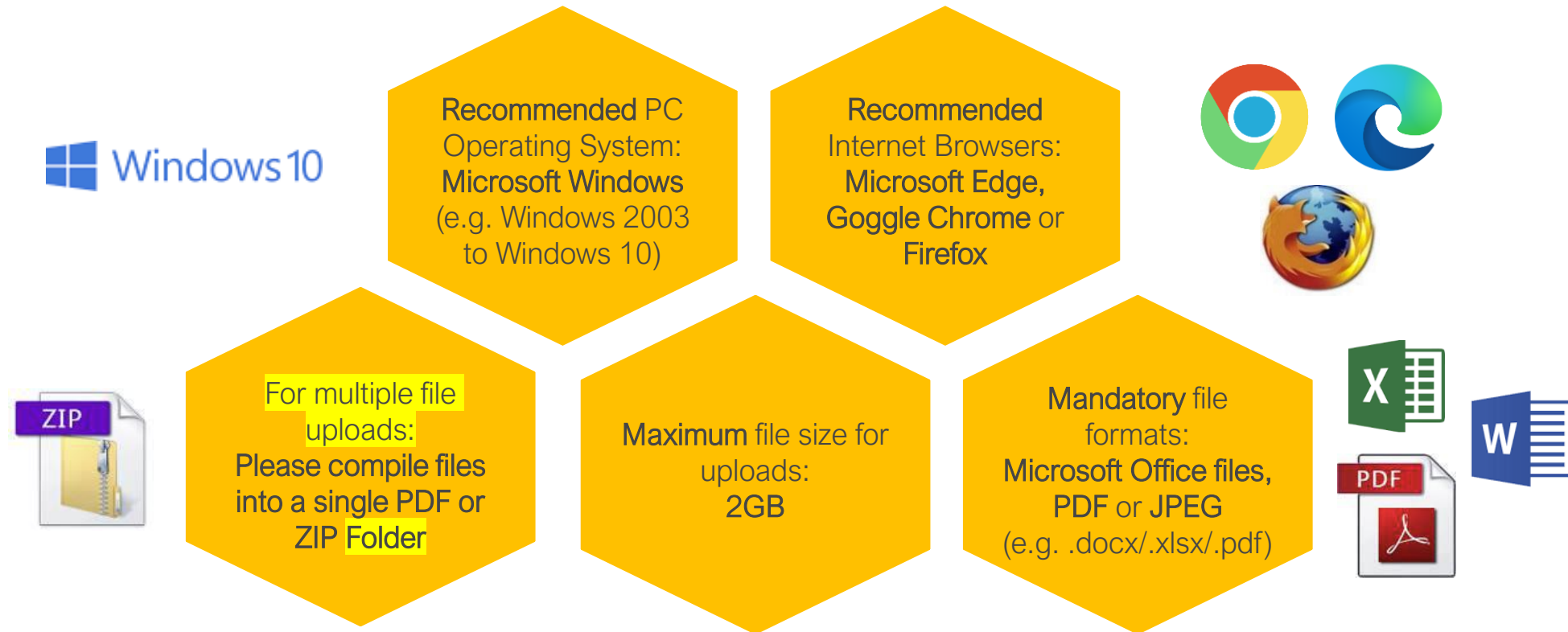

1.1 Application – Demonstration Overview



Once registered, Applicants can create an Application following the guidance within this document. Each applicant needs to ensure they complete their application in accordance with the CfD Regulations and the Allocation Framework. To see a demonstration overview of [how to navigate the CfD Portal and complete the application form](#), please refer to the [Allocation Round 5 Application Video](#) below.

[AR5 Application
Video Tutorial](#)

This video shows an overview of the Application form in the system. Click on the button above to watch the video. Note: some users may find these easier to access in Google Chrome.

[Recommended Portal
system requirements](#)

IMPORTANT

You must make sure that your computer and browser are compatible with the CfD Portal. Click on the button above to find out more.

Eligible Technologies for AR5



Pot 1 – Eligible Technologies and Applicable Delivery Years

Applicable Delivery Years	Technology Type	
2025/26, 2026/27 and 2027/28	Energy from Waste with CHP	Onshore Wind (>5MW)
	Hydro (>5MW and <50MW)	Remote Island Wind (>5MW)
	Landfill Gas	Sewage Gas
	Offshore Wind	Solar PV (>5MW)

Pot 2 – Eligible Technologies and Applicable Delivery Years

Applicable Delivery Years	Technology Type	
2026/27 and 2027/28	ACT	Geothermal
	Anaerobic Digestion (>5MW)	Tidal Stream
	Dedicated Biomass with CHP	Wave
	Floating Offshore Wind	

1.1 Application (Generic) – Overview



To complete a Contracts for Difference application, go to the [EMR Portal Home](#) and sign in using your username, password and pin as provided following successful company registration.

Electricity Market Reform

Electricity Market Reform (EMR) aims to deliver low carbon energy supplies whilst maintaining security of supply and minimising the cost to the consumer. EMR introduces two key mechanisms to provide incentives for the investment required in our energy infrastructure.



Latest News

REFRESH

[Updated Link for EMR Delivery Body New Portal Delivery Update Wednesday 1st...](#)
published 24 Jan 2023

[The Contracts for Difference Registration Window is now open for Allocation...](#)
published 23 Jan 2023

[Final T-1 and T-4 Capacity Market Auctions Guidelines are available and Con...](#)
published 23 Jan 2023

[Update on Capacity Market Training Auction](#)
published 18 Jan 2023

[Capacity Market Training Auction](#)
published 18 Jan 2023

1.1 Application (Generic) – Overview



Applicants will now be able to create a new application for Allocation Round 5.

Once logged into the EMR DB Portal, applicants should follow the below steps in order to start creating a new application:

Step 1: Select **My EMR**

Step 2: Select **Applications** from the Qualification module

Step 3: Select the **Create New Application** button

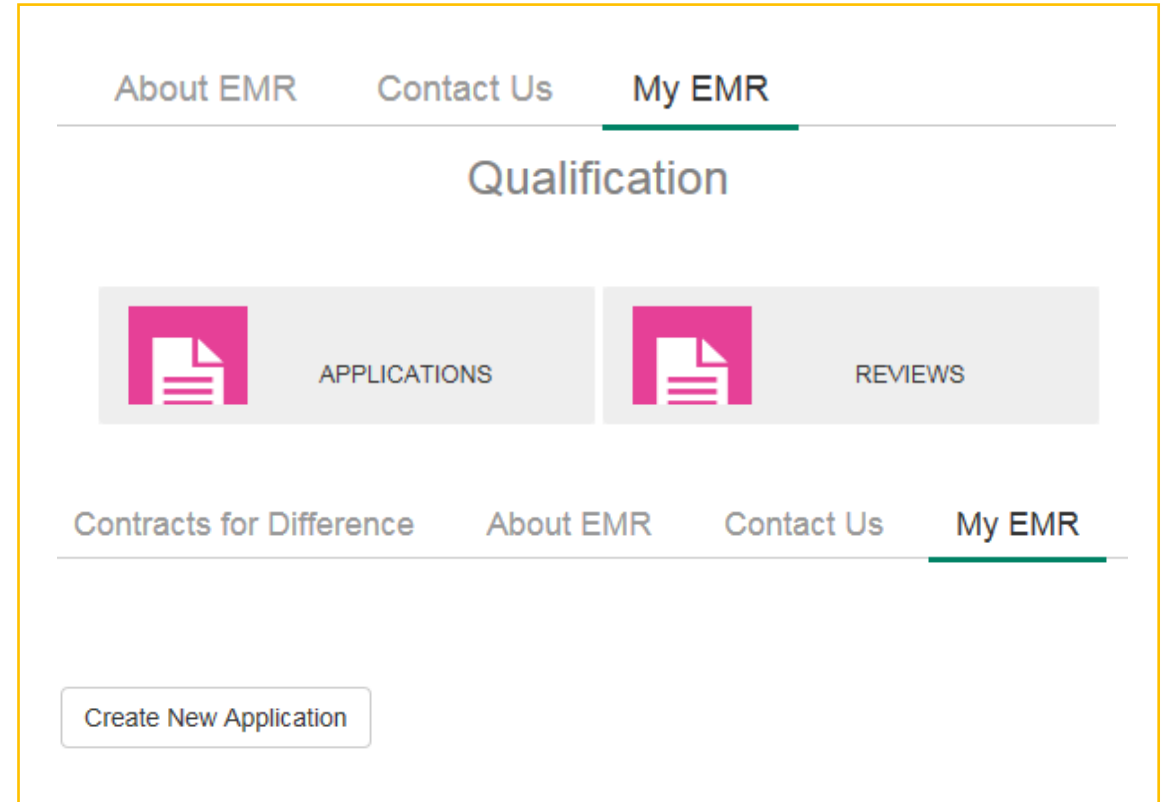

1.1 Application (Generic) – Overview



Once 'Create New application' has been selected, the following fields will appear:

Step 1: Select your **Company** from the drop-down menu and then confirm the Company.

Step 2: Select the **Technology Type** from the drop-down menu and select the box to confirm the Technology Type

Step 3: Select **Round 5** from the drop-down menu and confirm create.

Step 4: Tick the box to confirm you wish to create an application and select create.

This is a dynamic application form. Questions will be tailored dependent upon the Technology Type selected and answers provided in the application form.

The screenshot shows a dialog box titled "Create New Application" with a close button (X) in the top right corner. The dialog is divided into three sections:

- Step 1: Please confirm the company for which you wish to create an application for.** This section contains a dropdown menu with "CfD Test" selected and a checkbox labeled "I confirm this is my company".
- Step 2: Confirm Technology Type** This section contains an empty dropdown menu and a checkbox labeled "I confirm this is the correct Technology Type".
- Step 3: Confirm the Round for which you'd like to create an application for:** This section contains an empty dropdown menu and a checkbox labeled "I confirm I wish to create an Application for this round".

At the bottom of the dialog, there are two buttons: "Create" and "Cancel".

1.1 Application (Generic) – Overview



At the top of the Application form screen, you will see the following buttons:

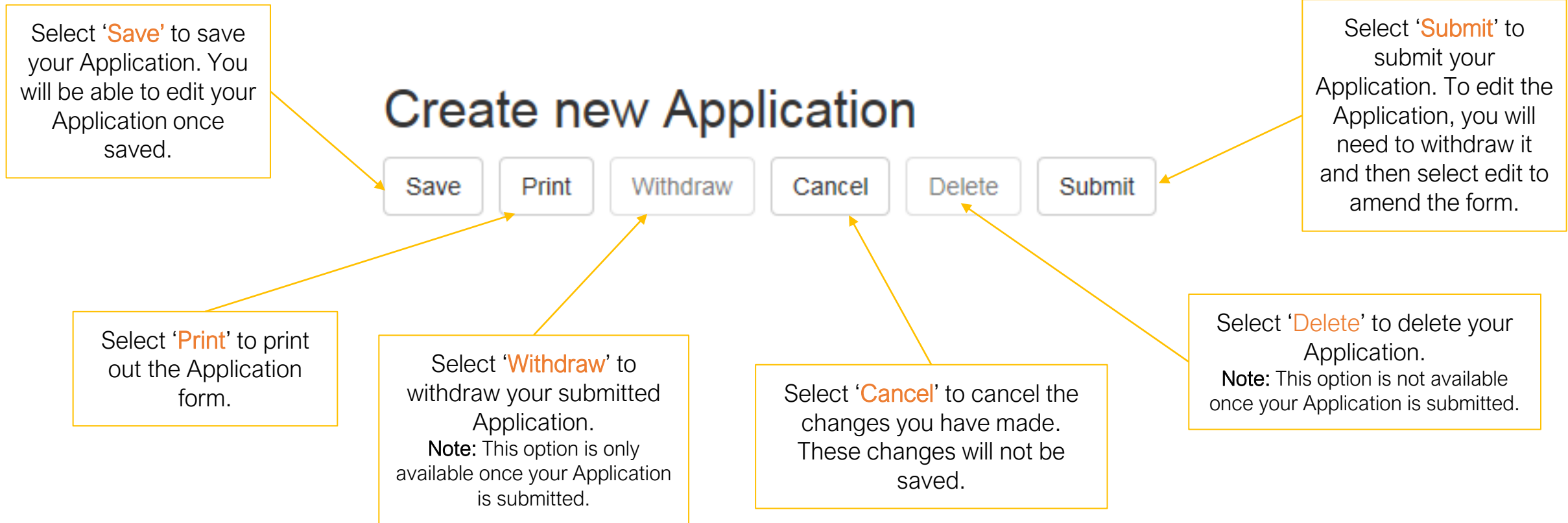

Note: An Application may be withdrawn by the Applicant up to and including the Application Window Closing Date. If an Auction is required, Applications can also be withdrawn up to the Sealed Bid Submission Closing Date, please refer to section [1.5 of the Application Guidance](#) for more information.

1.1 Application (Generic) – Overview



Once you have completed the “Create new applications window”, a blank application form will appear with 9 tabs.

The first tab that is pre-selected is the “General” tab.

Create new Application

Save Print Withdraw Cancel Delete Submit

General Incorporation CfD Unit Details Cross subsidy scheme Applicable plan. consents Connection Agreement(s)

CfD Contract Supply Chain Plan Declarations

Note:

(*) Questions marked with an asterisk are mandatory.

All other questions are non-mandatory but are used to support the assessment.

1.2 Application (Generic) – System View



The Application form is split up into 9 tabs (see below).

Select from the buttons below to see the system view of each section of the Application form:

Application Form Tab 1
General

Application Form Tab 2
Incorporation

Application Form Tab 2
CfD Unit Details

Application Form Tab 4
Cross Subsidy Check

Application Form Tab 5
Applicable Planning Consents

Application Form Tab 6
Connection Agreement(s)

Application Form Tab 7
CfD Contract

Application Form Tab 8
Supply Chain Plan

Application Form Tab 9
Declarations

Application Form Tab 1 General



1.2 Application (Generic) – System View



1. General tab

New A: Does any part of your CfD Unit overlap with any of the excluded sites to which a temporary site exclusion applies (as held by the Low Carbon Contracts Company)? (*)

Yes No

If 'Yes' is selected in New A, New B will appear and you will be required to upload your exemption certificate.

New B: Please provide a copy of your Exemption Certificate (*)

New C: Please select that your CfD Unit is located in Great Britain? (*)

Great Britain

Great Britain will appear in this field as default.

A9: Technology Type (*)

Apart from Offshore Wind, technologies can only have a single phase and are therefore identified as Phase 1 in this application form

The technology selected on the previous page will appear here.

A9: Technology Type (*)

Apart from Offshore Wind, technologies can only have a single phase and are therefore identified as Phase 1 in this application form

Offshore Wind

A10: Number of CfD Phases (*)

1
1
2
3

All technologies have a single phase, denoted by a '1', unless the CFD unit is Offshore Wind (fixed bottom only).

Where Offshore Wind is selected in A9, A10 will appear and you can select up to a maximum of 3 phases.

Application Form Tab 2 Incorporation



1.2 Application (Generic) – System View



2. Incorporation tab

The Incorporation tab is split into four sections: **Company/Applicant details**, **Agent details** (where applicable), **phase details** and **VAT details**.

The Company/Applicant details section can be seen below. Select the buttons below to see the system view for each type:

A2: Is the Application being made on behalf of a Company? (*)

Note that an Unincorporated Joint Venture is not a Company for the purposes of this question, If you are an Unincorporated Joint Venture , please answer "No" to this question.

Yes No

A2: Yes
the Application is on behalf of a
company

A2: No
the Application is on behalf of an
organisation

1.2 Application (Generic) – System View

2. Incorporation tab – Company details (1/2)

– Company Details

A3: Company Name (*)

CfD Test

A3a: Company Registered Address Line 1 (*)

1

A3b: Company Registered Address Line 2

A3c: Company Registered Address Line 3

A3d: City

1

A3e: Postcode (*)

1

A3f: Country in which Company is located (*)

United Kingdom



These details are completed as default from the company details provided at Registration.

1.2 Application (Generic) – System View



2. Incorporation tab – Company details (2/2)

A3g: Region (England, Wales, Scotland or Northern Ireland) where Company is located (*)

A3h: Email address of preferred contact (*)

A3i: Landline of authorised contact to be in format "+[2 digit country code] [NUMBER without leading 0]"

A3j: Mobile Number of authorised contact to be in the format "+[2 digit country code] [NUMBER without leading 0]" (*)

A3k: Fax Number of authorised contact to be in the format "+[2 digit country code] [NUMBER without leading 0]"

A4: Company Registration Number (*)

A4a: Please upload a copy of your Certificate of Incorporation (*)

A4b: Should your Certificate of Incorporation require any clarification, please provide it here

If Northern Ireland is selected from the dropdown, an [agent section](#) will appear that will need to be completed.

1.2 Application (Generic) – System View



2. Incorporation tab – Applicant details (other than Company/Corporate Body) (1/2)

– Applicant Details (where not a Company/Corporate Body)

A6: Do you have a Legal Personality that will allow you to enter into the CfD Contract? (*)

(Legal personality means to be capable of having legal rights and duties within a certain legal system such as to enter into contracts)

Yes No

A7: Name of Applicant (*)

CfD Test

A7a: Address Line 1 (*)

1

A7b: Address Line 2

A7c: Address Line 3

A7d: City

1

A7e: Postcode (*)

1

These details are completed as default from the company details provided at Registration.

If you are not a registered company you will be asked to complete A6 and New C0. Unincorporated Joint Ventures will need to provide supporting documentation.

New C0: Are you an Unincorporated Joint Venture? (*)

Yes No

New C1: Please provide a pdf setting out name, address and contact details of the parties involved in the Unincorporated Joint Venture

Browse...

1.2 Application (Generic) – System View



2. Incorporation tab – Applicant details (other than Company/Corporate Body) (2/2)

A7f: Country in which Applicant is located (*)

A7g: Region (England, Wales, Scotland or Northern Ireland) where Applicant is located (*)

A7h: Email address of preferred contact (*)

A7i: Landline of authorised contact to be in the format "+[2 digit country code] [NUMBER without leading 0]"

A7j: Mobile Number of authorised contact to be in the format "+[2 digit country code] [NUMBER without leading 0]" (*)

A7k: Fax Number of authorised contact to be in the format "+[2 digit country code] [NUMBER without leading 0]"

New C0: Are you an Unincorporated Joint Venture? (*)

 Yes No

New C1: Please provide a pdf setting out name, address and contact details of the parties involved in the Unincorporated Joint Venture

If Northern Ireland is selected from the dropdown, an [agent section](#) will appear that will need to be completed.

Enter the contact numbers of the Applicant. It is mandatory to provide at least the mobile number.

If 'Yes' is selected, then the field New C1 will appear.

1.2 Application (Generic) – System View



2. Incorporation tab – Agent details (1/2)

– Agent Details

A8: Name of Agent (*)

(Agent is to provide the powers of the contract to take effect as the legal powers wouldn't be able to be enforced outside their jurisdiction and so the Applicant would need someone within GB to apply on their behalf)

Enter the name of the Agent

A8a: Address Line 1 (*)

A8b: Address Line 2

A8c: Address Line 3

A8d: City

A8e: Postcode (*)

Enter the address details of the Agent
It is mandatory to complete the
address line 1 and the **postcode** fields

Note: Agent Details are only applicable if Northern Ireland is selected as the region.

1.2 Application (Generic) – System View



2. Incorporation tab – Agent details (2/2)

*Only applicable if Northern Ireland is selected as the region.

Enter the country and region of the location of the Agent.

A8f: Country in which Agent is located (*)

A8g: Region in which Agent is located (*)

Enter the email address of the Agent.

A8h: Email address (*)

A8i: Landline to be in the format "+[2 digit country code] [NUMBER without leading 0]"

A8j: Mobile Number to be in the format "+[2 digit country code] [NUMBER without leading 0]" (*)

A8k: Fax Number to be in the format "+[2 digit country code] [NUMBER without leading 0]"

Enter the contact numbers of the Agent. It is mandatory to provide at least the mobile number.

You do not need to provide a fax number.

1.2 Application (Generic) – System View



2. Incorporation tab – Phase details (1/4)

– Phases Details

A11: Will Applicant identified above be the Company/Person entering into CfD Contract for Phase 1? (*)

Yes No

A12: Name of Company/Person (*)

A12a: Address Line 1 (*) This needs to be the Company registered address if a Company

A12b: Address Line 2

A12c: Address Line 3

A12d: City

A12e: Postcode (*)

New C: Please select that your CfD Unit is located in Great Britain? (*)

Great Britain

A9: Technology Type (*)

Apart from Offshore Wind, technologies can only have a single phase and are therefore identified as Phase 1 in this application form

Offshore Wind

A10: Number of CfD Phases (*)

1
2
3

Note:

If the application is for multiple phases then details for the Company/Person entering into the CfD Contract must be populated for each phase, as each phase will have it's own contract generated. There will be an additional section in the application form for Phase 2 and 3.

All technologies will default to having 1 phase, unless the CfD unit is Offshore wind (fixed bottom only). The applicant is then required to enter the number of phases, up to a maximum of 3 phases. This must be specified in question A10 on the General tab.

1.2 Application (Generic) – System View



2. Incorporation tab – Phase details (2/4)

Applicant details for the Company/Person entering into CfD Contract for each Phase.

If 'Yes' is selected for A11, then the details from section A3 will be auto populated.

– Phases Details

A11: Will Applicant identified above be the Company/Person entering into CfD Contract for Phase 1? (*)

Yes No

If 'No' is selected to A11, then the applicant can enter the required details for the Company/Person who will be entering into the CfD Contract.

A12: Name of Company/Person (*)

A12a: Address Line 1 (*) This needs to be the Company registered address if a Company

A12b: Address Line 2

A12c: Address Line 3

A12d: City

A12e: Postcode (*)

If successful in being awarded a CfD, these details will be passed to the CfD Counterparty (the 'Low Carbon Contracts Company') to be used for generating the CfD Contract(s).

1.2 Application (Generic) – System View



2. Incorporation tab – Phase details (3/4)

– Phases Details

A11: Will Applicant identified above be the Company/Person entering into CfD Contract for Phase 1? (*)

Yes No

A12f: Country (*)	<input type="text" value="-"/>	Country in which Company/Person is located
A12h: Email address (*)	<input type="text"/>	
A12i: Landline	<input type="text"/>	to be in the format "+[2 digit country code] [NUMBER without leading 0]"
A12j: Mobile Number (*)	<input type="text"/>	to be in the format "+[2 digit country code] [NUMBER without leading 0]"
A12k: Fax Number	<input type="text"/>	to be in the format "+[2 digit country code] [NUMBER without leading 0]"
A12l: Company Registration Number (*)	<input type="text"/>	

If successful in being awarded a CfD, these details will be passed to the CfD Counterparty (the 'Low Carbon Contracts Company') to be used for generating the CfD Contract(s).

Note: If the application successful post allocation, and the Applicant has selected Yes to A11, then the details from A3 will be auto-populated from the company details section.

Please ensure these contact details are correct and regularly checked throughout the process.

1.2 Application (Generic) – System View



2. Incorporation tab – Phase details (4/4)

New D: Will the Applicant identified above be the Company/Person to whom notices under the CfD Contract be addressed for Phase 1? (*)

Yes No

If successful, these details will be passed to the CfD Counterparty (the 'Low Carbon Contracts Company') to be used for generating the CfD Contract(s).

A17: Name of Company/Person (*)	<input type="text"/>	For Phase 1, to whom should notices under the CfD Contract be addressed?
A17a: Address Line 1 (*)	<input type="text"/>	This needs to be the Company registered address if a Company
A17b: Address Line 2	<input type="text"/>	
A17c: Address Line 3	<input type="text"/>	
A17d: City	<input type="text"/>	
A17e: Postcode (*)	<input type="text"/>	
A17f: Country (*)	<input type="text" value="-"/>	Country where Party receiving notices under the CfD Contract is located
A17h: Email address (*)	<input type="text"/>	
A17i: Landline	<input type="text"/>	to be in the format "+[2 digit country code] [NUMBER without leading 0]"
A17j: Mobile Number (*)	<input type="text"/>	to be in the format "+[2 digit country code] [NUMBER without leading 0]"
A17k: Fax Number	<input type="text"/>	to be in the format "+[2 digit country code] [NUMBER without leading 0]"

Note:

If the application successful post allocation, and the Applicant has selected **Yes to New D**, then the details from **A3** will be auto-populated from the company details section. Including the email.

If **'No'** is selected to **New D**, then the applicant can enter the required details for the **Company/Person** who will be entering into the CfD Contract.

Please ensure these contact details are correct and regularly checked throughout the CFD allocation window

1.2 Application (Generic) – System View



2. Incorporation tab – VAT details

– VAT Details

A20: Are you registered for Tax in your host country (e.g. VAT registered in UK)? (*)

It is not mandatory to be registered for tax in your host country but if you select Yes here, you will need to provide VAT Registration Number or equivalent and upload VAT Certificate of Registration/Tax Certificate

Yes No

A21: VAT Registration Number (*)

(VAT Registration Number to be 9 digits long)

A21a: Please upload a copy of your VAT Certificate of Registration (*)

Choose file No file chosen

A21b: Should your Registration documentation require any clarification, please provide it here

If 'Yes' is selected, the following fields will appear and your VAT certificate of registration needs to be uploaded.

NB: Group VAT Certificate can be uploaded, but you will need to demonstrate that the subsidiary company is part of the parent company. i.e. a letter signed and dated by a current Director.

Application Form Tab 3 CfD Unit Details



1.2 Application (Generic) – System View



3. CfD Unit details tab (1/7)

CfD Unit Details

B1: Name of CfD Unit (Phase 1) (*)

B1a: Address Line 1 (*)
If no address for site, provide the centre of the nearest onshore substation

B1b: Address Line 2

B1c: Address Line 3

B1d: City

B1e: Postcode (*)

B1f: Country in which CfD Unit (Phase 1) is located (*)
United Kingdom ▼

B1g: Region in which CfD Unit (Phase 1) is located (*)
- ▼

Note:
If the proposed CfD Unit is located Offshore, then please provide the address details of the nearest onshore substation.

Please complete the details of the specific CfD Unit, you are applying for.

1.2 Application (Generic) – System View



3. CfD Unit details tab (2/7)

B2: Ordnance Survey Map Reference(s) to centre of site where CfD Unit (Phase 1) is located (centre of nearest onshore substation if Offshore Wind, Hydroelectric Power, Wave or Tidal Stream) and must be in the following format:

1st Letter will be N, T, S or H, 2nd Letter one of A (North West corner) to Z (South East corner) except I, 6 Numbers (3 digits for each Eastings and Northings - i.e. within each square how far from the SW corner of the square) (*)

B3: Grid Coordinates: Latitude in WGS84 format to 3 decimal places of Northerly extreme coordinate of site where CfD Unit (Phase 1) is located (*)

B3a: Grid Coordinates: Longitude in WGS84 format to 3 decimal places of Northerly extreme coordinate of site where CfD Unit (Phase 1) is located (*)

B3b: Grid Coordinates: Latitude in WGS84 format to 3 decimal places of Easterly extreme coordinate of site where CfD Unit (Phase 1) is located (*)

B3c: Grid Coordinates: Longitude in WGS84 format to 3 decimal places of Easterly extreme coordinate of site where CfD Unit (Phase 1) is located (*)

B3d: Grid Coordinates: Latitude in WGS84 format to 3 decimal places of Southerly extreme coordinate of site where CfD Unit (Phase 1) is located (*)

B3e: Grid Coordinates: Longitude in WGS84 format to 3 decimal places of Southerly extreme coordinate of site where CfD Unit (Phase 1) is located (*)

B3f: Grid Coordinates: Latitude in WGS84 format to 3 decimal places of Westerly extreme coordinate of site where CfD Unit (Phase 1) is located (*)

B3g: Grid Coordinates: Longitude in WGS84 format to 3 decimal places of Westerly extreme coordinate of site where CfD Unit (Phase 1) is located (*)

New G: Please provide a map showing scale, shape of CfD Unit and identify Longitude and Latitude (in WGS84 format to 3 decimal places) of Northerly, Easterly, Southerly and Westerly extreme coordinates of site where CfD Unit (Phase 1) is located (*)

B10: Is this Phase 1 CfD Application for Established (New) or Altered (Additional) capacity? (*)
Applicant should refer to Eligibility Regulations Clause 3, Part 5(a) and (b) for definitions of established and altered

B11: Provisional Capacity Estimate (Gross capacity minus parasitic loads minus electrical losses) for the CfD Unit Phase 1 (in MW to 2 decimal places)

For Altered(additional) capacity, only state the additional MW

If Offshore and >1 Phase, then Provisional Capacity Estimate for the CfD Unit Phase 1 must be >=25% of the sum of Initial Installed Capacity Estimates for all phases (*)

Locational information is requested for the CfD Unit.
An address example is shown on the next page.

Note:
Please ensure a **Map of the CfD Unit** is uploaded and meets the Allocation Framework definitions of a Map.

1.2 Application (Generic) – System View



3. CfD Unit details tab (3/7)

The Applicant will be asked to declare that the CfD Unit is not in receipt of subsidies for the CM, CfD, NFFO, SRO (see section 2.1.2 below).

The Delivery Body checks the location of the CfD unit details against public data, to identify the shape and boundary of the site and to ensure that the CfD Unit being applied for is not already in receipt of these subsidies.

Grid Reference
SP 29600 64000
Grid Reference (6 figure)
SP296640
X (Easting) : **429600** Y (Northing) : **264000**
Latitude : **52.273361** Longitude : **-1.5676159**
Address (near) :
National Grid House, Warwick Technology Park, Warwick, Warwickshire, West
Postcode (nearest) :
CV34 6DA

An Example of Address references cells populated:

B2: Ordnance Survey Map Reference(s) to centre of site where CfD Unit (Phase 1) is located (centre of nearest Power, Wave or Tidal Stream) and must be in the following format:
1st Letter will be N, T, S or H, 2nd Letter one of A (North West corner) to Z (South East corner) except I, 6 Num within each square how far from the SW corner of the square) (*)

B3: Grid Coordinates: Latitude in WGS84 format to 3 decimal places of Northerly extreme coordinate of site where CfD Unit (Phase 1) is located (*)

B3a: Grid Coordinates: Longitude in WGS84 format to 3 decimal places of Northerly extreme coordinate of site where CfD Unit (Phase 1) is located (*)

1.2 Application – System View



3. CfD Unit details tab – Remote Island Wind Applicants ONLY (4/7)

For all other technologies please continue to the next page

For applicants choosing Remote Island Wind (RIW) there is an additional question titled, B10. It is a requirement to upload a schematic diagram demonstrating that the RIW condition in Reg. 27A (3) (d) has been met.

New G: Please provide a map showing scale, shape of CfD Unit and identify Longitude and Latitude (in WGS84 format to 3 decimal places) of Northerly, Easterly, Southerly and Westerly extreme coordinates of site where CfD Unit (Phase 1) is located (*)

New B10: Please upload evidence demonstrating that the relevant CfD Unit is expected, as at the Target Commissioning Date, to satisfy the Remote Island Wind condition set out at Regulation 27A(3)(d) of the Contracts for Difference (Allocation) Regulations 2014 (as may be amended or modified by the Allocation Framework) (*)

B10: Is this Phase 1 CfD Application for Established (New) or Altered (Additional) capacity? (*)
Applicant should refer to Eligibility Regulations Clause 3, Part 5(a) and (b) for definitions of established and altered

For more information on RIW see [here](#)

1.2 Application – System View



3. CfD Unit details tab – Floating Offshore Wind ONLY (5/7)

For all other technologies please continue to the next page

For applicants choosing Floating Offshore Wind (FOW) there are additional questions titled, New G(i), New G(ii) and New G(iii). You will need to upload 2 documents here, as specified, and make a declaration that all turbines forming part of the relevant CfD Unit are situated in offshore waters of at least 45 metres depth. These conditions are referenced in the [CfD \(Miscellaneous Amendments\) Regulations 2021](#) – Regulation 27ZA.

New G: Please provide a map showing scale, shape of CfD Unit and identify Longitude and Latitude (in WGS84 format to 3 decimal places) of Northerly, Easterly, Southerly and Westerly extreme coordinates of site where CfD Unit (Phase 1) is located (*)

No file chosen

New G(i): Please upload a colour-coded depth chart of the consented area to demonstrate that the CfD Unit will be situated in an area with water of sufficient depth to be eligible as FoW. As stated in CfD Allocation Regulations 2014 (Misc. Amendments) 2021 (*)

No file chosen

New G(ii): It is a requirement that all turbines forming part of the relevant CFD unit are situated in offshore waters of at least 45 metres depth (measured from the seabed to chart datum). Please confirm all turbines of the relevant CfD Unit situated in offshore waters of at least 45 metres depth (measured from the seabed to chart datum). (*)

By selecting the response "Yes" the Applicant is making the declaration above.

Yes No

New G(iii): It is a requirement of Applicants to provide a declaration, signed by a Director, stating that the relevant CFD Unit will meet all the floating offshore wind conditions. Please upload a declaration, signed by a Director. As stated in CfD Allocation Regulations 2014 (Misc. Amendments) 2021 (*)

No file chosen

1.2 Application (Generic) – System View



3. CfD Unit details tab (6/7)

B10: Is this Phase 1 CfD Application for Established (New) or Altered (Additional) capacity? (*)

Applicant should refer to Eligibility Regulations Clause 3, Part 5(a) and (b) for definitions of established and altered

B11: Provisional Capacity Estimate (Gross capacity minus parasitic loads minus electrical losses) for the CfD Unit Phase 1 (in MW to 2 decimal places)

For Altered(additional) capacity, only state the additional MW

If Offshore and >1 Phase, then Provisional Capacity Estimate for the CfD Unit Phase 1 must be $\geq 25\%$ of the sum of Initial Installed Capacity Estimates for all phases

(*)

B12: Target Commissioning Date for Phase 1 Date must be in format DD/MM/YYYY (*)

B13: Delivery Year for Phase 1 (*)

B14: Target Commissioning Window Start Date for Phase 1 (*)

Must be set so that the Target Commissioning Date for Phase 1 falls within the Target Commissioning Window for Phase 1

Date must be in format DD/MM/YYYY

B15: Target Commissioning Window End Date for Phase 1 (*)

Note: For Solar PV Projects the Provisional Capacity Estimate must be entered MW of AC power (MWAC).

Note: The latest date the “Target Commissioning Date” can fall, with the exception of secondary phases of Phased Offshore Wind CFD Units, is the last day of the final Delivery Year.

Note: The earliest date that the “Target Commissioning Window Start Date” can fall is such that the final day of the Target Commissioning Window falls on the first day of the applicable Delivery Year.

1.2 Application (Generic) – System View



3. CfD Unit details tab (7/7)

B28: Reference price that applies to the CFD Unit (*)

B31: Please provide whether your CfD Unit is Round 2 or Round 3/Scottish Territorial Waters? (*)

B32: Please provide a copy of your Crown Estate Lease/Agreement for Lease in respect of the location of your CfD Unit (*)

B32a: Should your Crown Estate Lease/Agreement for Lease require any clarification, please provide it here

Note: B31, B32, B32a - Only asked if answer to Question A9 =

- Offshore Wind or;
- Floating Offshore Wind

Upload a copy of your Crown Estate/Agreement for Lease for the OFTO as well as the CfD unit

Application Form Tab 4 Cross Subsidy



1.2 Application (Generic)



4. Cross subsidy check tab (1/2)

Regulation 14 of the Contracts for Difference (Allocation) Regulations 2014 and Schedule 5 of the CfD [AR5 Allocation Framework 2022](#) specify that an Applicant is excluded from applying for a CfD if they are in receipt of the subsidies listed in section 2.1.2 below.

See [section 2.1.2](#) for further information about the cross subsidy check

The Delivery Body will check that the: name, postcode, geographic coordinates, and/or the Ordnance Survey Grid Reference of the CfD Unit specified is not a site where an accreditation applies (except where separate metering arrangements mean it is not an excluded application).

1.2 Application (Generic) – System View



4. Cross subsidy check tab (2/2)

C1: Is the CfD Unit accredited in the Renewables Obligation or has a current application for accreditation with Ofgem? (*)

By selecting "Yes" the Applicant is making the declaration that a renewables obligation "accreditation" or an application for "accreditation", which has not yet been determined, applies or has applied to the relevant CfD Unit.

By selecting "No" the Applicant is making the declaration that neither a renewables obligation "accreditation" nor an application for "accreditation", which has not yet been determined, applies or has applied to the relevant CfD Unit.

Applicants selecting "Yes" will be identified as Dual Scheme Plant and will be asked to identify the Type of Dual Scheme Plant

Yes No

If 'Yes' is selected in C1, the fields C2 and C4 will appear.

C2: Type of Dual Scheme Plant (*)

Additional Capacity



-
Phased Offshore Wind CfD Unit
Biomass Conversion
Additional Capacity

C4: What is the capacity to 2 decimal places in MW of the whole station? (*)

For Biomass Conversion this will default to the answer provided to Question B30

C6, C7, C8 – These declarations are confirming if the Applicant is or is not in receipt of other Government subsidies as specified in Schedule 5 of the CfD [AR5 Allocation Framework 2022](#).

Application Form Tab 5 Planning Consent(s)



1.2 Application (Generic)



5. Applicable planning consents tab

As part of normal project construction and operation, a generation project may require several planning consents both for the generation facility and to connect to a Transmission or Distribution Network. Only certain types of consents are relevant for CfD Qualification; these are known as 'Applicable Planning Consents'. Below are some pertinent questions to help you decide which 'Applicable Planning Consents' you may need to provide with your CfD Application.

-
- 1 What planning consents do I need for the CfD Unit and to get power to the Transmission/Distribution/Private Wire Network?

 - 2 Which are Applicable Planning Consents as defined in the Allocation Regulations?

 - 3 Which of the above relate to works to which both a Connection Agreement applies, and those works are undertaken by a person other than the Applicant?

 - 4 Planning Decision Notice for each Applicable Planning Consent where works undertaken by Applicant.

 - 5 Declare that Applicable Planning Consents provided apply to the CfD Unit and cover works for the CfD Unit to get power to the Transmission/Distribution/Private Wire Network (or the relevant network operator are obtaining such consents on Applicant's behalf, and this is covered in Connection Agreement(s)).
-

1.2 Application (Generic)



5. Applicable planning consents – Qualification

Applicant Checklist

Applicant to provide the relevant Planning Decision Notice for each Applicable Planning Consent that applies to the CfD Unit.

**If the expiry date is prior to the date of CfD Application, then provide appropriately signed and dated supporting evidence to clarify that the expiry date is extended to the date after date of CfD Application.*

ESO

The Delivery Body checks:

- Location & technology consistency
- MW in planning decision notice \geq capacity applied for
- Planning Decision Notice has not expired at the date of the CfD Application*

1.2 Application (Generic)



5. Applicable planning consents – Qualification

Evidence requirements:

Acceptable evidence



Planning Decision Notice

Unacceptable evidence



Planning committee meeting minutes



Outline Planning Permission

1.2 Application (Generic) – System View



5. Applicable planning consents tab

General Incorporation CfD Unit Details Cross subsidy scheme

Applicable plan. consents Connection Agreement(s) CfD Contract Supply Chain Plan

Declarations

Applicable planning consents

+ Development Order

+ Transport and Works Act Order

+ Planning permission

+ Section 36

+ Marine Licence

NB. Within the Applicable Planning Consents tab, open each Planning Consent that is applicable to you by pressing the '+' symbol to expand the questions

Question D41 is available for all planning types.

D41: Confirm that the applicable planning consents provided apply to the CfD Unit and cover the works to allow the CfD Unit to supply electricity to the transmission, distribution or private wire network (or the DNO/TNO are obtaining such consents on their behalf and this is covered in connection agreement(s))

Applicable Planning Consents are limited to those identified in Allocation Regulation 24

By selecting the response 'Yes' the Applicant is making a declaration of compliance with Allocation Regulation 23 (*)

Yes No

1.2 Application (Generic)



5. Applicable planning consents tab

The applicable planning consents tab is split into five sections.
Select the buttons below to see the system view for each applicable planning consent.

*If the CfD Unit is an offshore wind project in Welsh waters

Development Order

Transport and Works Act
Order*

Planning Permission

Section 36 Consent

Marine Licence

Note: Copies of all applicable planning consent(s), should include a signed and dated Planning Decision Notice, where relevant. If the Planning Consent has expired, evidence of authorised extension must be provided. Where planning consents specify a technology, if that technology differs to the technology on the Application form, clarification evidence must be provided.

1.2 Application (Generic) – System View



5. Applicable planning consents tab – Development Order (1/6)

Applicable planning consents

– Development Order

D1: Is a Development Order one of your applicable planning consents? This is the Development Consent Order under section 114 of Planning Act (*)

Yes No

D2: Provide reason why Development Order is not required for your CfD Unit (*)

If D9 = No, D10 will appear.

Note: Applicants are required to provide the reason as to why the applicable planning consent is not required for the CfD Unit.

See the next slide for the questions that appear if 'Yes' is selected in the D1 field.

1.2 Application (Generic) – System View



5. Applicable planning consents tab – Development Order (2/6)

– Development Order

D1: Is a Development Order one of your applicable planning consents? This is the Development Consent Order under section 114 of Planning Act (*)

Yes No

D1a: It is a requirement of Applicants to provide a copy of their Development Order. Please upload a copy of your Development Order (*)

No file chosen

D1b: Should your Development Order require any clarification, please provide it here

If 'Yes' is selected in field D1, the following question path will appear.

D3: Where available, provide Ordnance Survey Map Reference from your Development Order

D3a: Where available, indicate the reference of the document where the Ordnance Survey Map Reference can be found

D3b: Where available, indicate the page number of the document where the Ordnance Survey Map Reference can be found

D3c: Provide any further comments on your Ordnance Survey Map Reference which will help us to identify this as the location of your CfD Application

1.2 Application (Generic) – System View



5. Applicable planning consents tab – Development Order (3/6)

D4: Where available, provide Postcode from your Development Order

D4a: Where available, indicate the reference of the document where the postcode can be found

D4b: Where available, indicate the page number of the document where the postcode can be found

D4c: Provide any further comments on your Postcode which will help us to identify this as the location of your CfD Application

If 'Yes' is selected in field D1, the following question path will appear.

D5: Where available, provide the Northerly Grid Coordinates (WGS84 format) from your Development Order

1.2 Application (Generic) – System View



5. Applicable planning consents tab – Development Order (4/6)

D5b: Where available, provide the Southerly Grid Coordinates (WGS84 format) from your Development Order

If 'Yes' is selected in field D1, the following question path will appear.

D5c: Where available, provide the Westerly Grid Coordinates (WGS84 format) from your Development Order

D5d: Where available, indicate the reference of the document where the Grid Coordinates (WGS84 format) can be found

D5e: Where available, indicate the page number of the document where the Grid Coordinates (WGS84 format) can be found

D5f: Provide any further comments on your Grid Coordinates (WGS84 format) which will help us to identify this as the location of your CfD Application

1.2 Application (Generic) – System View



5. Applicable planning consents tab – Development Order (5/6)

D6: Where available, provide the capacity in MW from your Development Order

D6a: Where available, indicate the reference of the document where the capacity in MW can be found

D6b: Where available, indicate the page number of the document where the capacity in MW can be found

D6c: Provide any further comments on the Development Order, which will help us validate the capacity in MW of your CfD Application

If 'Yes' is selected in field D1, the following question path will appear.

D7: Where available, provide the date (in format DD/MM/YYYY) by when the applicable planning consents expire in your Development Order

D7a: Where available, indicate the reference of the document where the date by when the applicable planning consents expire can be found

1.2 Application (Generic) – System View



5. Applicable planning consents tab – Development Order (6/6)

D7b: Where available, indicate the page number of the document where the date by when the applicable planning consents expire can be found

D7c: Provide any further comments on the Development Order, which will help us confirm that it has not expired

If 'Yes' is selected in field D1, the following question path will appear.

D8: Where available, provide technology type from your Development Order

D8a: Where available, indicate the reference of the document where the technology type can be found

D8b: Where available, indicate the page number of the document where the technology type can be found

D8c: Provide any further comments on your technology type which will help us to identify this as the technology in your CfD Application

1.2 Application (Generic) – System View



5. Applicable planning consents tab – Transport and Works Act Order (1/4)

**only applicable to offshore wind in Welsh waters.*

Note: This Question Path will only be visible for applicants who have selected Offshore Wind to be located in Wales.

Applicable planning consents

+ Development Order

– Transport and Works Act Order

D9: Is a Transport and Works Act Order one of your applicable planning consents? This is the Order under section 3 of the Transport and Works Act 1992 (*)

Yes No

– Transport and Works Act Order

D9: Is a Transport and Works Act Order one of your applicable planning consents? This is the Order under section 3 of the Transport and Works Act 1992 (*)

Yes No

D10: Provide reason why Transport and Works Act Order is not required for your CfD Unit (*)

If D9 = No, D10 will appear.

Note: Applicants are required to provide the reason as to why the applicable planning consent is not required for the CfD Unit.

1.2 Application (Generic) – System View



5. Applicable planning consents tab – Transport and Works Act Order (2/4)

**only applicable to offshore wind in Welsh waters.*

– Transport and Works Act Order

D9: Is a Transport and Works Act Order one of your applicable planning consents? This is the Order under section 3 of the Transport and Works Act 1992 (*)

Yes No

D9a: It is a requirement of Applicants to provide a copy of their Transport and Works Act Order. Please upload a copy of your Transport and Works Act Order (*)

Browse...

D9b: Should your Transport and Works Act Order require any clarification, please provide it here

D11: Where available, provide Ordnance Survey Map Reference from your Transport and Works Act Order

D11a: Where available, indicate the reference of the document where the Ordnance Survey Map Reference can be found

D11b: Where available, indicate the page number of the document where the Ordnance Survey Map Reference can be found

D11c: Provide any further comments on your Ordnance Survey Map Reference which will help us to identify this as the location of CfD Application

D12: Where available, provide Postcode from your Transport and Works Act Order

D12a: Where available, indicate the reference of the document where the postcode can be found

D12b: Where available, indicate the page number of the document where the postcode can be found

D12c: Provide any further comments on your Postcode which will help us to identify this as the location of your CfD Application

If D9 = Yes, D9a – D16c will appear.
Click [here](#) for an example of locational data

Questions D9b – D16c are not mandatory, but assist the Delivery Body in the Application Assessment process.

1.2 Application (Generic) – System View



5. Applicable planning consents tab – Transport and Works Act Order (3/4)

**only applicable to offshore wind in Welsh waters.*

D13: Where available, provide the Northerly Grid Coordinates (WGS84 format) from your Transport and Works Act Order

D13a: Where available, provide the Easterly Grid Coordinates (WGS84 format) from your Transport and Works Act Order

D13b: Where available, provide the Southerly Grid Coordinates (WGS84 format) from your Transport and Works Act Order

D13c: Where available, provide the Westerly Grid Coordinates (WGS84 format) from your Transport and Works Act Order

D13d: Where available, indicate the reference of the document where the Grid Coordinates (WGS84 format) can be found

D13e: Where available, indicate the page number of the document where the Grid Coordinates (WGS84 format) can be found

If D9 = Yes, D9a – D16c will appear.
Click [here](#) for an example of locational data

D13f: Provide any further comments on your Grid Coordinates (WGS84 format) which will help us to identify this as the location of your CfD Application

D14: Where available, provide the capacity in MW from your Transport and Works Act Order

D14a: Where available, indicate the reference of the document where the capacity in MW can be found

D14b: Where available, indicate the page number of the document where the capacity in MW can be found

D14c: Provide any further comments on the Transport and Works Act Order, which will help us validate the capacity in MW of your CfD Application

Questions D9b – D16c are not mandatory, but assist the Delivery Body in the Application Assessment process.

1.2 Application (Generic) – System View



5. Applicable planning consents tab – Transport and Works Act Order (4/4)

**only applicable to offshore wind in Welsh waters.*

D15: Where available, provide the date (in format DD/MM/YYYY) by when the applicable planning consents expire in your Transport and Works Act Order

D15a: Where available, indicate the reference of the document where the date by when the applicable planning consents expire can be found

D15b: Where available, indicate the page number of the document where the date by when the applicable planning consents expire can be found

D15c: Provide any further comments on the Transport and Works Act Order, which will help us confirm that it has not expired

D16: Where available, provide technology type from your Transport and Works Act Order

D16a: Where available, indicate the reference of the document where the technology type can be found

D16b: Where available, indicate the page number of the document where the technology type can be found

D16c: Provide any further comments on your technology type which will help us to identify this as the technology in your CfD Application

If D9 = Yes, D9a – D16c will appear.
Click [here](#) for an example of locational data

Questions D9b – D16c are not mandatory, but assist the Delivery Body in the Application Assessment process.

1.2 Application (Generic) – System View



5. Applicable planning consents tab – Planning permission (1/6)

– Planning permission

D17: Is a Planning Permission one of your applicable planning consents?

In England and Wales this is permission under Part 3 of the Town and Country Planning Act 1990.

In Scotland this is permission under Part 3 of the Town and Country Planning (Scotland) Act 1997. (*)

Yes No

D18: Provide reason why Planning Permission is not required for your CfD Unit (*)

If D17 = No, D18 will appear.

Note: Applicants are required to provide the reason as to why the applicable planning consent is not required for the CfD Unit.

See the next slide for the questions that appear if 'Yes' is selected in the D17 field.

1.2 Application (Generic) – System View



5. Applicable planning consents tab – Planning permission (2/6)

If D17 = Yes, D17a – D24c will appear.

D17a: It is a requirement of Applicants to provide a copy of their Planning Permission. Please upload a copy of your Planning Permission. (*)

Browse...

D17b: Should your Planning Permission require any clarification, please provide it here

D19: Where available, provide Ordnance Survey Map Reference from your Planning Permission

D19a: Where available, indicate the reference of the document where the Ordnance Survey Map Reference can be found

D19b: Where available, indicate the page number of the document where the Ordnance Survey Map Reference can be found

D19c: Provide any further comments on your Ordnance Survey Map Reference which will help us to identify this as the location of your CfD Application

Questions D17b – D24c are not mandatory, but assist the Delivery Body in the Application Assessment process.

1.2 Application (Generic) – System View



5. Applicable planning consents tab – Planning permission (3/6)

If D17 = Yes, D17a – D24c will appear.

D20: Where available, provide Postcode from your Planning Permission

D20a: Where available, indicate the reference of the document where the postcode can be found

D20b: Where available, indicate the page number of the document where the postcode can be found

D20c: Provide any further comments on your Postcode which will help us to identify this as the location of your CfD Application

D21: Where available, provide the Northerly Grid Coordinates (WGS84 format) from your Planning Permission

D21a: Where available, provide the Easterly Grid Coordinates (WGS84 format) from your Planning Permission

Questions D17b – D24c are not mandatory, but assist the Delivery Body in the Application Assessment process.

1.2 Application (Generic) – System View



5. Applicable planning consents tab – Planning permission (4/6)

If D17 = Yes, D17a – D24c will appear.

D21b: Where available, provide the Southerly Grid Coordinates (WGS84 format) from your Planning Permission

D21c: Where available, provide the Westerly Grid Coordinates (WGS84 format) from your Planning Permission

D21d: Where available, indicate the reference of the document where the Grid Coordinates (WGS84 format) can be found

D21e: Where available, indicate the page number of the document where the Grid Coordinates (WGS84 format) can be found

D21f: Provide any further comments on your Grid Coordinates (WGS84 format) which will help us to identify this as the location of your CfD Application

Questions D17b – D24c are not mandatory, but assist the Delivery Body in the Application Assessment process.

1.2 Application (Generic) – System View



5. Applicable planning consents tab – Planning permission (5/6)

If D17 = Yes, D17a – D24c will appear.

D22: Where available, provide the capacity in MW from your Planning Permission

D22a: Where available, indicate the reference of the document where the capacity in MW can be found

D22b: Where available, indicate the page number of the document where the capacity in MW can be found

D22c: Provide any further comments on the Planning Permission, which will help us validate the capacity in MW of your CfD Application

D23: Where available, provide the date (in format DD/MM/YYYY) by when the applicable planning consents expire in your Planning Permission

D23a: Where available, indicate the reference of the document where the date by when the applicable planning consents expire can be found

Questions D17b – D24c are not mandatory, but assist the Delivery Body in the Application Assessment process.

1.2 Application (Generic) – System View



5. Applicable planning consents tab – Planning permission (6/6)

If D17 = Yes, D17a – D24c will appear.

D23b: Where available, indicate the page number of the document where the date by when the applicable planning consents expire can be found

D23c: Provide any further comments on the Planning Permission, which will help us confirm that it has not expired

D24: Where available, provide technology type from your Planning Permission

D24a: Where available, indicate the reference of the document where the technology type can be found

D24b: Where available, indicate the page number of the document where the technology type can be found

D24c: Provide any further comments on your technology type which will help us to identify this as the technology in your CfD Application

Questions D17b – D24c are not mandatory, but assist the Delivery Body in the Application Assessment process.

1.2 Application (Generic) – System View



5. Applicable planning consents tab – Section 36 consent (1/6)

– Section 36

D25: Is a Section 36 one of your applicable planning consents? This is Consent under section 36 of the Electricity Act 1989 (*)

Yes No

D26: Provide reason why Section 36 is not required for your CfD Unit (*)

If D25 = No, D26 will appear.

Note: Applicants are required to provide the reason as to why the applicable planning consent is not required for the CfD Unit.

See the next slide for the questions that appear if 'Yes' is selected in the D25 field.

1.2 Application (Generic) – System View



5. Applicable planning consents tab – Section 36 consent (2/6)

If D25 = Yes, D25a – D32c will appear.

D25a: It is a requirement of Applicants to provide a copy of their Section 36. Please upload a copy of your Section 36. (*)

Browse...

D25b: Should your Section 36 require any clarification, please provide it here

D27: Where available, provide Ordnance Survey Map Reference from your Section 36

D27a: Where available, indicate the reference of the document where the Ordnance Survey Map Reference can be found

D27b: Where available, indicate the page number of the document where the Ordnance Survey Map Reference can be found

D27c: Provide any further comments on your Ordnance Survey Map Reference which will help us to identify this as the location of your CfD Application

Questions D25b – D32c are not mandatory, but assist the Delivery Body in the Application Assessment process.

1.2 Application (Generic) – System View



5. Applicable planning consents tab – Section 36 consent (3/6)

If D25 = Yes, D25a – D32c will appear.

D28: Where available, provide Postcode from your Section 36

D28a: Where available, indicate the reference of the document where the postcode can be found

D28b: Where available, indicate the page number of the document where the postcode can be found

D28c: Provide any further comments on your Postcode which will help us to identify this as the location of your CfD Application

D29: Where available, provide the Northerly Grid Coordinates (WGS84 format) from your Section 36

D29a: Where available, provide the Easterly Grid Coordinates (WGS84 format) from your Section 36

Questions D25b – D32c are not mandatory, but assist the Delivery Body in the Application Assessment process.

1.2 Application (Generic) – System View



5. Applicable planning consents tab – Section 36 consent(4/6)

If D25 = Yes, D25a – D32c will appear.

D29b: Where available, provide the Southerly Grid Coordinates (WGS84 format) from your Section 36

D29c: Where available, provide the Westerly Grid Coordinates (WGS84 format) from your Section 36

D29d: Where available, indicate the reference of the document where the Grid Coordinates (WGS84 format) can be found

D29e: Where available, indicate the page number of the document where the Grid Coordinates (WGS84 format) can be found

D29f: Provide any further comments on your Grid Coordinates (WGS84 format) which will help us to identify this as the location of your CfD Application

Questions D25b – D32c are not mandatory, but assist the Delivery Body in the Application Assessment process.

1.2 Application (Generic) – System View



5. Applicable planning consents tab – Section 36 consent (5/6)

If D25 = Yes, D25a – D32c will appear.

D30: Where available, provide the capacity in MW from your Section 36

D30a: Where available, indicate the reference of the document where the capacity in MW can be found

D30b: Where available, indicate the page number of the document where the capacity in MW can be found

D30c: Provide any further comments on the Section 36, which will help us validate the capacity in MW of your CfD Application

D31: Where available, provide the date (in format DD/MM/YYYY) by when the applicable planning consents expire in your Section 36

D31a: Where available, indicate the reference of the document where the date by when the applicable planning consents expire can be found

Questions D25b – D32c are not mandatory, but assist the Delivery Body in the Application Assessment process.

1.2 Application (Generic) – System View



5. Applicable planning consents tab – Section 36 consent(6/6)

If D25 = Yes, D25a – D32c will appear.

D31b: Where available, indicate the page number of the document where the date by when the applicable planning consents expire can be found

D31c: Provide any further comments on the Section 36, which will help us confirm that it has not expired

D32: Where available, provide technology type from your Section 36

D32a: Where available, indicate the reference of the document where the technology type can be found

D32b: Where available, indicate the page number of the document where the technology type can be found

D32c: Provide any further comments on your technology type which will help us to identify this as the technology in your CfD Application

Questions D25b – D32c are not mandatory, but assist the Delivery Body in the Application Assessment process.

1.2 Application (Generic) – System View



5. Applicable planning consents tab – Marine Licence (1/6)

– Marine Licence

D33: Is a Marine Licence one of your applicable planning consents?

This is Under Part 4 of the Marine and Coastal Act 2009 or in Scottish marine area (section 1 of the Marine (Scotland) Act 2010) Part 4 of the Marine (Scotland) Act 2010 (*)

Yes No

D34: Provide reason why Marine Licence is not required for your CfD Unit (*)

If D33 = No, D34 will appear.

Note: Applicants are required to provide the reason as to why the applicable planning consent is not required for the CfD Unit.

See the next slide for the questions that appear if 'Yes' is selected in the D34 field.

1.2 Application (Generic) – System View



5. Applicable planning consents tab – Marine Licence (2/6)

If D25 = Yes, D33a – D40c will appear.

D33a: It is a requirement of Applicants to provide a copy of their Marine Licence. Please upload a copy of your Marine Licence. (*)

Browse...

D33b: Should your Marine Licence require any clarification, please provide it here

D35: Where available, provide Ordnance Survey Map Reference from your Marine Licence

D35a: Where available, indicate the reference of the document where the Ordnance Survey Map Reference can be found

D35b: Where available, indicate the page number of the document where the Ordnance Survey Map Reference can be found

D35c: Provide any further comments on your Ordnance Survey Map Reference which will help us to identify this as the location of your CfD Application

Questions D33b – D40c are not mandatory, but assist the Delivery Body in the Application Assessment process.

1.2 Application (Generic) – System View



5. Applicable planning consents tab – Marine Licence (3/6)

If D25 = Yes, D33a – D40c will appear.

D36: Where available, provide Postcode from your Marine Licence

D36a: Where available, indicate the reference of the document where the postcode can be found

D36b: Where available, indicate the page number of the document where the postcode can be found

D36c: Provide any further comments on your Postcode which will help us to identify this as the location of your CfD Application

D37: Where available, provide the Northerly Grid Coordinates (WGS84 format) from your Marine Licence

D37a: Where available, provide the Easterly Grid Coordinates (WGS84 format) from your Marine Licence

Questions D33b – D40c are not mandatory, but assist the Delivery Body in the Application Assessment process.

1.2 Application (Generic) – System View



5. Applicable planning consents tab – Marine Licence (4/6)

If D25 = Yes, D33a – D40c will appear.

D37b: Where available, provide the Southerly Grid Coordinates (WGS84 format) from your Marine Licence

D37c: Where available, provide the Westerly Grid Coordinates (WGS84 format) from your Marine Licence

D37d: Where available, indicate the reference of the document where the Grid Coordinates (WGS84 format) can be found

D37e: Where available, indicate the page number of the document where the Grid Coordinates (WGS84 format) can be found

D37f: Provide any further comments on your Grid Coordinates (WGS84 format) which will help us to identify this as the location of your CfD Application

Questions D33b – D40c are not mandatory, but assist the Delivery Body in the Application Assessment process.

1.2 Application (Generic) – System View



5. Applicable planning consents tab – Marine Licence (5/6)

If D25 = Yes, D33a – D40c will appear.

D38: Where available, provide the capacity in MW from your Marine Licence

D38a: Where available, indicate the reference of the document where the capacity in MW can be found

D38b: Where available, indicate the page number of the document where the capacity in MW can be found

D38c: Provide any further comments on the Marine Licence, which will help us validate the capacity in MW of your CfD Application

D39: Where available, provide the date (in format DD/MM/YYYY) by when the applicable planning consents expire in your Marine Licence

D39a: Where available, indicate the reference of the document where the date by when the applicable planning consents expire can be found

Questions D33b – D40c are not mandatory, but assist the Delivery Body in the Application Assessment process.

1.2 Application (Generic) – System View



5. Applicable planning consents tab – Marine Licence (6/6)

If D25 = Yes, D33a – D40c will appear.

D39b: Where available, indicate the page number of the document where the date by when the applicable planning consents expire can be found

D39c: Provide any further comments on the Marine Licence, which will help us confirm that it has not expired

D40: Where available, provide technology type from your Marine Licence

D40a: Where available, indicate the reference of the document where the technology type can be found

D40b: Where available, indicate the page number of the document where the technology type can be found

D40c: Provide any further comments on your technology type which will help us to identify this as the technology in your CfD Application

Questions D33b – D40c are not mandatory, but assist the Delivery Body in the Application Assessment process.

Application Form Tab 6 Connection Agreement(s)



1.2 Application (Generic) – System View



6. Connection Agreement(s) Tab

There are three “types of connection” that can be selected in the Connection Agreement tab:

- Direct Connection, or;
- Partial Connection, or;
- Islanded CfD Unit. (“Islanded CfD Unit” is a historic term for Private Wire network, it does not refer to RIW)

Where the connection agreement specifies a technology, which is different from the technology on the application, evidence must be provided to clarify this. Where the company name on the connection agreement differs to that in the application, evidence must be provided to clarify this.

Select the buttons below to see the system view for each connection type

E1: Type of Connection (*)

Confirm type of connection that applies to the CfD Unit?

Direct
Partial
Islanded CfD Unit

Select the ‘Type of Connection’ from the dropdown menu, which is applicable to the CfD Unit.

Direct Connection

Partial Connection

Islanded CfD unit

Note: The relevant Connection Agreement provided must be signed and dated in order to be valid.

1.2 Application (Generic)



6. Connection Agreement(s) – Direct Connection - Qualification

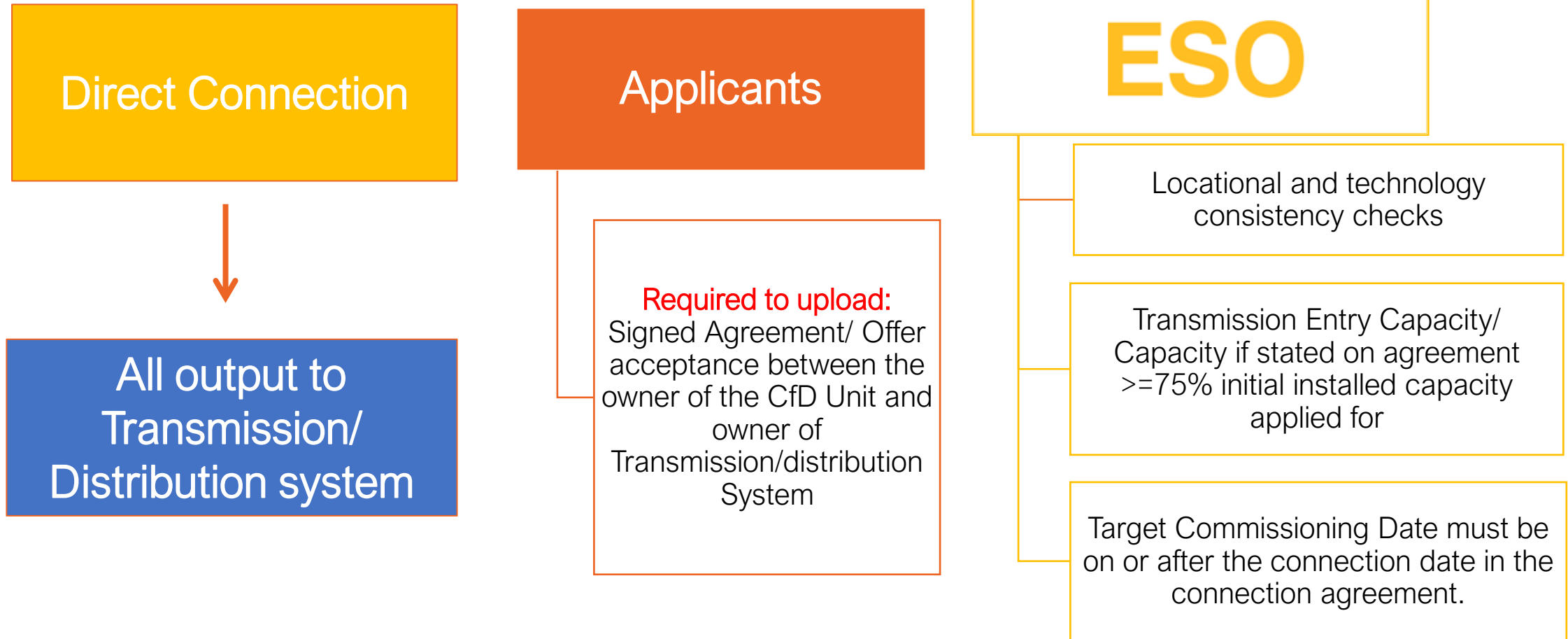

Note: The relevant Connection Agreement provided must be signed and dated in order to be valid.

1.2 Application (Generic) – System View



6. Connection Agreement(s) tab – Direct Connection

E1: Type of Connection (*)

Confirm type of connection that applies to the CfD Unit?

E2: Confirm if transmission or distribution connection (*)

Select Transmission or Distribution from the drop down menu.

Direct & Transmission

Direct & Distribution

Note: Where there is a difference in the name on the connection agreement and application, clarificatory evidence is required.

1.2 Application (Generic) – System View



6. Connection Agreement(s) tab – Direct Connection

Note: E3, E4 and E5 will appear for Offshore Wind Technology only.

E3: Does single metering or apportioned metering apply for Phase 1? (*)

Do you intend to treat phases as individual projects for the purposes of metering ('single metering') or use an apportionment methodology to assign net generation to each individual phase ('apportioned metering')

E4: Does single metering or apportioned metering apply for Phase 2? (*)

E5: Does single metering or apportioned metering apply for Phase 3? (*)

1.2 Application (Generic) – System View



6. Connection Agreement(s) tab – Direct & Transmission (1/4)

E1: Type of Connection (*)

Confirm type of connection that applies to the CfD Unit?

E2: Confirm if transmission or distribution connection (*)

E7: Please provide a copy of connection agreement(s)/countersigned offer(s) between Applicant and the Transmission System Operator. (*)

E16: Where available, provide location from your connection agreement(s)/countersigned offer(s)

E16a: Where available, indicate the reference of the document where the location can be found

E16b: Where available, indicate the page number of the document where the location can be found

E16c: Provide any further comments on your location which will help us to identify this as the location of your CfD Application

Note: Where there is a difference in the name on the connection agreement and application, clarificatory evidence is required.

1.2 Application (Generic) – System View



6. Connection Agreement(s) tab – Direct & Transmission (2/4)

E1: Type of Connection (*)

Confirm type of connection that applies to the CfD Unit?

E2: Confirm if transmission or distribution connection (*)

E17: Where available, provide the Transmission Entry Capacity in MW from your connection agreement(s)/countersigned offer(s)

E17a: Where available, indicate the reference of the document where the Transmission Entry Capacity in MW can be found

E17b: Where available, indicate the page number of the document where the Transmission Entry Capacity in MW can be found

E17c: Provide any further comments on the connection agreement(s)/countersigned offer(s) which will help us validate the Transmission Entry Capacity in MW of your CfD Application

1.2 Application (Generic) – System View



6. Connection Agreement(s) tab – Direct & Transmission (3/4)

E1: Type of Connection (*)

Confirm type of connection that applies to the CfD Unit?

E2: Confirm if transmission or distribution connection (*)

E18: Where available, provide the Connection Date (in format DD/MM/YYYY) from your connection agreement(s)/countersigned offer(s)

E18a: Where available, indicate the reference of the document where the Connection Date can be found

E18b: Where available, indicate the page number of the document where the Connection Date can be found

E18c: Provide any further comments on the connection agreement(s)/countersigned offer(s) which will help us validate the Connection Date of your CfD Application

1.2 Application (Generic) – System View



6.Connection Agreement(s) tab – Direct & Transmission (4/4)

E1: Type of Connection (*)

Confirm type of connection that applies to the CfD Unit?

Direct



E2: Confirm if transmission or distribution connection (*)

Transmission



E19: Where available, provide technology type from your connection agreement(s)/countersigned offer(s)

-



E19a: Where available, indicate the reference of the document where the technology type can be found

E19b: Where available, indicate the page number of the document where the technology type can be found

E19c: Provide any further comments on your technology type which will help us to identify this as the technology in your CfD Application

1.2 Application (Generic) – System View



6.Connection Agreement(s) tab – Direct & Distribution (1/4)

E1: Type of Connection (*)

Confirm type of connection that applies to the CfD Unit?

E2: Confirm if transmission or distribution connection (*)

E6: Are you intending to be 'licence exempt embedded' or 'licence connected'? (Please refer to definitions in Schedule 1 of the Allocation Framework) (*)

E8: Please provide a copy of connection agreement(s)/countersigned offer(s) between Applicant and the Distribution Network Operator. (*)

Note: E6 is only asked if:
Direct is selected in E1, and
Distribution is selected in E2.

E20: Where available, provide location from your connection agreement(s)/countersigned offer(s)

E20a: Where available, indicate the reference of the document where the location can be found

E20b: Where available, indicate the page number of the document where the location can be found

E20c: Provide any further comments on your location which will help us to identify this as the location of your CfD Application

NB. where there is a difference in the name on the connection agreement and application, clarificatory evidence is required.

1.2 Application (Generic) – System View



6. Connection Agreement(s) tab – Direct & Distribution (2/4)

E1: Type of Connection (*)

Confirm type of connection that applies to the CfD Unit?

E2: Confirm if transmission or distribution connection (*)

E21: Where available, provide the Capacity in MW from your connection agreement(s)/countersigned offer(s)

E21a: Where available, indicate the reference of the document where the Capacity in MW can be found

E21b: Where available, indicate the page number of the document where the Capacity in MW can be found

E21c: Provide any further comments on the connection agreement(s)/countersigned offer(s) which will help us validate the Capacity in MW of your CfD Application

1.2 Application (Generic) – System View



6. Connection Agreement(s) tab – Direct & Distribution (3/4)

E1: Type of Connection (*)

Confirm type of connection that applies to the CfD Unit?

E2: Confirm if transmission or distribution connection (*)

E22: Where available, provide the Connection Date (in format DD/MM/YYYY) from your connection agreement(s)/countersigned offer(s)

E22a: Where available, indicate the reference of the document where the Connection Date can be found

E22b: Where available, indicate the page number of the document where the Connection Date can be found

E22c: Provide any further comments on the connection agreement(s)/countersigned offer(s) which will help us validate the Connection Date of your CfD Application

1.2 Application (Generic) – System View



6. Connection Agreement(s) tab – Direct & Distribution (4/4)

E1: Type of Connection (*)

Confirm type of connection that applies to the CfD Unit?

E2: Confirm if transmission or distribution connection (*)

E23: Where available, provide technology type from your connection agreement(s)/countersigned offer(s)

E23a: Where available, indicate the reference of the document where the technology type can be found

E23b: Where available, indicate the page number of the document where the technology type can be found

E23c: Provide any further comments on your technology type which will help us to identify this as the technology in your CfD Application

1.2 Application (Generic)



6. Connection Agreement(s) – Partial Connection Qualification

Partial Connection



Output to Transmission/
Distribution System and
Private Wire Network

Applicants

Required to upload:
Signed Agreement/Offer acceptance
between the owner of the CfD Unit
and owner of Transmission/
Distribution System*; and

Private Network Use
Agreement (where the
Generator is not the operator of
Private Network)*

ESO

Locational and technology
consistency checks

* **Note:** a copy of the Connection Agreement applicable to the CfD Unit which allows for such connection to the relevant Transmission System, Distribution System or Private Wire Network.
This agreement needs to be signed and dated to ensure validity during the Application Window.

* CfD Unit and operator of Private Network can be the same entity

1.2 Application (Generic) – System View



6. Connection Agreement(s) tab – Partial Connection

Select the buttons below to see the system view for each connection type:

E1: Type of Connection (*)

Confirm type of connection that applies to the CfD Unit?

E2: Confirm if transmission or distribution connection (*)

Select **Transmission** or **Distribution** from the drop down menu.

E9: Are you or will you be the operator of Private Wire network to which the CfD Unit exports or is to export electricity? (*)

Yes No

E9: Yes, the operator of the Private Wire Network

E9: No, not the operator of the Private Wire Network

Note: where there is a difference in the name on the connection agreement and application, clarificatory evidence is required.

1.2 Application (Generic) – System View



6. Connection Agreement(s) tab – Partial & Yes to E9 – Operator of Private Wire Network (1/2)

E9: Are you or will you be the operator of Private Wire network to which the CfD Unit exports or is to export electricity? (*)

Yes No

E10: Please provide a copy of connection agreement(s)/countersigned offer(s) between Applicant and the Transmission System Operator or Relevant Distribution Network Operator. (*)

Browse...

E24: Where available, provide location from your connection agreement(s)/countersigned offer(s)

E24a: Where available, indicate the reference of the document where the location can be found

E24b: Where available, indicate the page number of the document where the location can be found

E24c: Provide any further comments on your location which will help us to identify this as the location of your CfD Application

1.2 Application (Generic) – System View



6. Connection Agreement(s) tab – Partial & Yes to E9 – operator of Private Wire Network (2/2)

E1: Type of Connection (*)

Confirm type of connection that applies to the CfD Unit?

E25: Where available, provide technology type from your connection agreement(s)/countersigned offer(s)

E25a: Where available, indicate the reference of the document where the technology type can be found

E25b: Where available, indicate the page number of the document where the technology type can be found

E25c: Provide any further comments on your technology type which will help us to identify this as the technology in your CfD Application

Note: Where the connection agreement specifies a technology, which is different from the technology on the application, evidence must be provided to clarify this.

1.2 Application (Generic) – System View



6. Connection Agreement(s) tab – Partial & No to E9 – “I am not the operator of Private Wire Network” (1/4)

E1: Type of Connection (*)

Confirm type of connection that applies to the CfD Unit?

E11: Please provide a copy of connection agreement(s)/countersigned offer(s) between Operator of Private Wire Network and Transmission System Operator or Relevant Distribution Network Operator. (*)

E12: Please provide a copy of the Private Network Use Agreement between Applicant and Operator of Private Wire Network. (*)

E26: Where available, provide location from your connection agreement(s)/countersigned offer(s)

E26a: Where available, indicate the reference of the document where the location can be found

E26b: Where available, indicate the page number of the document where the location can be found

E26c: Provide any further comments on your location which will help us to identify this as the location of your CfD Application

1.2 Application (Generic) – System View



6. Connection Agreement(s) tab – Partial & No to E9 – “I am not the operator of Private Wire Network” (2/4)

E1: Type of Connection (*)

Confirm type of connection that applies to the CfD Unit?

E27: Where available, provide technology type from your connection agreement(s)/countersigned offer(s)

E27a: Where available, indicate the reference of the document where the technology type can be found

E27b: Where available, indicate the page number of the document where the technology type can be found

E27c: Provide any further comments on your technology type which will help us to identify this as the technology in your CfD Application

Note: Where the connection agreement specifies a technology, which is different from the technology on the application, evidence must be provided to clarify this.

1.2 Application (Generic) – System View



6. Connection Agreement(s) tab – Partial & No to E9 – “I am not the operator of Private Wire Network” (3/4)

E1: Type of Connection (*)

Confirm type of connection that applies to the CfD Unit?

E28: Where available, provide location from your Private Network Use Agreement

E28a: Where available, indicate the reference of the document where the location can be found

E28b: Where available, indicate the page number of the document where the location can be found

E28c: Provide any further comments on your location which will help us to identify this as the location of your CfD Application

1.2 Application (Generic) – System View



6. Connection Agreement(s) tab – Partial & No to E9 – “I am not the operator of Private Wire Network” (4/4)

E1: Type of Connection (*)

Confirm type of connection that applies to the CfD Unit?

E29: Where available, provide technology type from your Private Network Use Agreement

E29a: Where available, indicate the reference of the document where the technology type can be found

E29b: Where available, indicate the page number of the document where the technology type can be found

E29c: Provide any further comments on your technology type which will help us to identify this as the technology in your CfD Application

1.2 Application (Generic)



6. Connection Agreement(s) – Private Network CfD Unit - Qualification

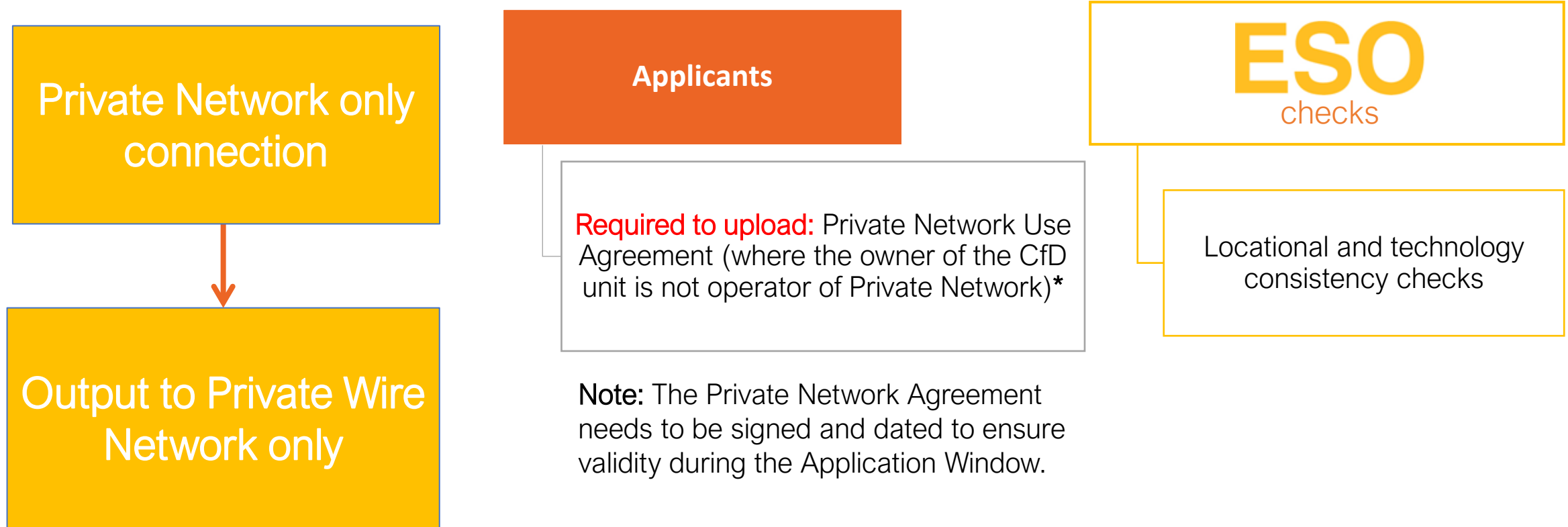

* The owner of the CfD unit and operator of Private Network can be the same entity

1.2 Application (Generic) – System View



6. Connection Agreement(s) tab – Private Network CfD Unit (1/4)

NB E1. will refer to “Islanded CfD Unit” this is a historic term and has the same meaning as Private Wire network.

Connection Agreement(s)

E1: Type of Connection (*)

Confirm type of connection that applies to the CfD Unit?

Islanded CfD Unit



If you are the Operator of the Private Wire Network, you only need answer E9 and the declaration in Question E13

E9: Are you or will you be the operator of Private Wire network to which the CfD Unit exports or is to export electricity? (*)

Yes No

E13: Where an Islanded CfD Unit, please confirm that no Direct connection or Partial connection currently or will exist in the future (*)

By selecting the response "Yes" the Applicant is making this declaration

Yes No

Note: where there is a difference in the name on the connection agreement and application, evidence must be provided to clarify this.

1.2 Application (Generic) – System View



6. Connection Agreement(s) tab – Private Network CfD Unit (2/4)

If 'No' is selected in E9, the following fields will appear.

E1: Type of Connection (*)

Confirm type of connection that applies to the CfD Unit?

Note: Remote Island Wind Applicants do not have the option of Islanded CfD unit.

E9: Are you or will you be the operator of Private Wire network to which the CfD Unit exports or is to export electricity? (*)

Yes No

E12: Please provide a copy of the Private Network Use Agreement between Applicant and Operator of Private Wire Network. (*)

E13: Where an Islanded CfD Unit, please confirm that no Direct connection or Partial connection currently or will exist in the future (*)

By selecting the response "Yes" the Applicant is making this declaration

Yes No

Note: E13 is not available to Remote Island Wind Applicants.

1.2 Application (Generic) – System View



6. Connection Agreement(s) tab – Private Network CfD Unit (3/4)

The following fields only appears if 'No' is selected in E9:

E28: Where available, provide location from your Private Network Use Agreement

E28a: Where available, indicate the reference of the document where the location can be found

E28b: Where available, indicate the page number of the document where the location can be found

E28c: Provide any further comments on your location which will help us to identify this as the location of your CfD Application

1.2 Application (Generic) – System View



6. Connection Agreement(s) tab – Private Network CfD Unit (4/4)

The following fields only appears if 'No' is selected in E9:

E29: Where available, provide technology type from your Private Network Use Agreement

E29a: Where available, indicate the reference of the document where the technology type can be found

E29b: Where available, indicate the page number of the document where the technology type can be found

E29c: Provide any further comments on your technology type which will help us to identify this as the technology in your CfD Application

Note: Where the connection agreement specifies a technology, which is different from the technology that the application, evidence must be provided to clarify this.

1.2 Application (Generic)



6. Connection Agreement Checklist – Qualification Assessment

Acceptable evidence



Countersigned agreement with Transmission System Operator



Distribution Offer signed by Distribution Network Operator (DNO) and Generator's signed offer acceptance



Evidence of Distribution Offer from DNO and Generator's signed offer acceptance

Unacceptable evidence



Unsigned Distribution Offer acceptance by Generator



No evidence of Distribution Offer from DNO

Application Form Tab 7 CfD Contract



1.2 Application (Generic) – System View



7. CfD Contract tab (1/3)

F1: Which CfD Agreement are you entering into? (*)

-
- Generic
- Private Wire
- Phased (Single metering)
- Phased (Apportioned metering)
- Unincorporated Joint Venture Agreement

Select 1 option from the drop down list. Options are varied dependent upon your technology. Here all options are listed.

F2: Have you agreed to use the Standard Terms or agreed a Modification Agreement with the LCCC? (*)

-
- Standard Terms
- Modification Agreement

Select 'Standard Terms' or 'Modification Agreement' from the dropdown menu. See the next slide for the fields that appear for each option.

1.2 Application (Generic) – System View



7. CfD Contract tab – Standard Terms or Modification Agreement (2/3)

Standard
Terms

F2: Have you agreed to use the Standard Terms or agreed a Modification Agreement with the LCCC? (*)

Standard Terms

F3: Please provide version number of Standard Terms (*)

The version number of the Standard Terms will be confirmed no later than 20 days prior to the Allocation Round Opening*.

Modification
Agreement

F2: Have you agreed to use the Standard Terms or agreed a Modification Agreement with the LCCC? (*)

Modification Agreement

F4: Please provide reference number for Modification Agreement (*)

F5: Please provide date that Modification Agreement was agreed with LCCC (*)

If Modification Agreement has been selected then Applicants must provide the reference number and the date the modification was agreed with LCCC.

***Note:** The version number for the CfD Allocation Round 5: Standard Terms and Conditions is Version 5, 16 March 2023.

1.2 Application (Generic) – System View



7. CfD Contract Tab – Private Wire CfD Agreement additional Declarations (3/3)

F1: Which CfD Agreement are you entering into? (*)

Private Wire

-
- Generic
- Private Wire**
- Phased (Single metering)
- Phased (Apportioned metering)
- Unincorporated Joint Venture Agreement

The Applicant selects “Private Wire” from the drop down list.

A Private Wire CfD Agreement can only be selected if the applicant has answered either ‘Partial’ or ‘Islanded CfD Unit’ to Question E1 on the Connection Agreement Type.

New F6 (i): To be eligible to apply for a Private Network CfD Agreement, it is a requirement for the applicant to be a Private Network Generator (as defined in Schedule 1 of the Allocation Framework). Please confirm that the Applicant is a Private Network Generator (*)

By selecting the response "Yes" the Applicant is making the declaration above.

Yes No

New F6 (ii): It is a requirement of Applicants to provide a declaration, signed by a Director, stating that the applicant is a Private Network Generator and meets the full definition of Private Network Generator (as defined in Schedule 1 of the Allocation Framework). Please upload a declaration, signed by a Director, as stated in Schedule 5 of the CfD Allocation Framework (*)

Choose File No file chosen

If “Private Wire” is selected for the CfD Agreement Type, it is now a requirement to confirm that the Applicant is a “Private Network Generator”* and provide a signed directors declaration.

*Further details and the definition of Private Network Generator can be found in Schedule 5 of the Allocation Framework.

Application Form Tab 8 Supply Chain Plan



1.2 Application (Generic) – System View



8. Supply Chain Plan tab (for projects of 300MW or above)

If the capacity entered in the CfD Unit Details Tab is equal to or greater than 300 MW, or the Technology Type is Floating Offshore Wind, then the applicant must provide a statement by the Secretary of State for the Department for Energy Security and Net Zero approving the Supply Chain Plan submitted in respect of that station, and section G1 will appear as below.

General Incorporation CfD Unit Details Cross subsidy scheme Applicable plan. consents Connection Agreement(s)

CfD Contract **Supply Chain Plan** Declarations

Supply Chain Plan

G1: Please provide copy of Approval Certificate for Supply Chain Plan (*)

Note: For Allocation Round 5, the Supply Chain Plan approval statement is required for all Floating Offshore Wind Projects, regardless of capacity.

If the CfD unit capacity or technology type does not require a supply chain plan certificate to be uploaded, then no questions will be visible.

General Incorporation CfD Unit Details Cross subsidy scheme Applicable plan. consents Connection Agreement(s)

CfD Contract Supply Chain Plan Declarations

Supply Chain Plan

Nothing to fill-in currently on this tab

Application Form Tab 9 Declarations



1.2 Application (Generic) – System View



9. Declaration Tab – applicable for all applications (1/4)

H1: Each Applicant must declare that the Application is one to which an allocation process applies in the allocation round (*)

By selecting the response "Yes" the Applicant is making the declaration above.

Yes No

H2: Each Applicant must declare that the Application is not an excluded application. (*)

By selecting the response "Yes" the Applicant is making the declaration above.

Yes No

H3: Each Applicant must declare that the Application meets the general qualification requirements set out or referred to in Chapter 3 of the Allocation Regulations, as amended or modified by the Allocation Framework (*)

By selecting the response "Yes" the Applicant is making the declaration above.

Yes No

H4: Each Applicant must declare that the Application, where applicable, meets the additional qualification requirements set out or referred to in Chapter 4 of the Allocation Regulations, as amended or modified by the Allocation Framework (*)

By selecting the response "Yes" the Applicant is making the declaration above.

Yes No

H5: Each Applicant must declare that included in the form which comprises part of the Application is the information necessary to enable the “delivery body” to: make the determination under paragraph (1) of Regulation 17 of the Allocation Regulations; and give the “CFD notification” were the Application to be a “successful application”, including information listed or referred to in Schedule 1 of the Allocation Regulations. (*)

By selecting the response "Yes" the Applicant is making the declaration above.

Yes No

H6: Each Applicant must declare that in all material respects, all information provided with or in the Application is true and correct (and to the extent that a copy of a document has been provided, that it is a true and correct copy). (*)

By selecting the response "Yes" the Applicant is making the declaration above.

Yes No

All Applicants are required to complete the Declarations in H1 – H6

1.2 Application (Generic) – System View



9. Declaration tab – Additional Declarations for ACT Applicants (2/4)

Declaration **H7** - ACT applicants must provide a process flow diagram demonstrating that the CfD Unit will meet the Physical Separation Requirement as defined in the most recently published version of the CfD Standard Terms and Conditions.

H7 only
appears for
ACT
Applicants

H7 : Please upload a process flow diagram demonstrating that the CfD Unit will meet the Physical Separation Requirement defined in the most recently published version of the CfD Standard Terms and Conditions. It should show that at all times the Synthesis Chamber and Combustion Chamber will be separated by a conduct or pipe:

- a. which will be used for transporting the Advanced Fuel produced in the Synthesis Chamber to the Combustion Chamber;
- b. which will include at least one connection that allows for sampling of the Advanced Fuel;
- c. within which no combustion will occur; and
- d. which has an operating Compression Unit or Purification Unit within it or connected to it.

By uploading the diagram, the applicant confirms they intend to satisfy the Physical Separation Requirement defined in the most recently published version of the CfD Standard Terms and Conditions. (*)

Browse...

If your Technology Type is **ACT**, remember to upload a process flow diagram.
[Click here for further information.](#)

1.2 Application (Generic) – System View



9. Declaration tab – Additional Declarations for Dedicated Biomass & Energy from Waste Applicants (3/4)

Declaration **H8** - Dedicated Biomass (i.e. those technologies which must deploy with CHP) must declare that they are aware of the requirement in CfD contract terms to accredit under the CHPQA standard and to deliver a valid CHPQA certificate to LCCC as and when required.

H8: Each Applicant must declare that they are aware that the CfD Agreement requires a valid CHPQA Certificate in respect of the project to be delivered to the CfD Counterparty as a 'Further Condition Precedent'. (*)

By selecting the response "Yes" the Applicant is making the declaration above.

Yes No

1.2 Application (Generic) – System View



9. Declaration tab – Additional Declarations for Floating Offshore Wind Applicants (4/4)

The mandatory declarations H9 and H10 will only be visible for applicants who are applying for a Floating Offshore Wind CfD Unit

H9: It is a requirement that the relevant floating offshore wind CFD unit is not a phased offshore wind CFD unit (or any other offshore wind CFD unit that is to be established or altered in phases of construction). Please confirm that the relevant floating offshore wind CFD unit is not a phased offshore wind CFD unit (or any other offshore wind CFD unit that is to be established or altered in phases of construction). (*)

By selecting the response "Yes" the Applicant is making the declaration above.

Yes No

H10: It is a requirement that all turbines forming part of the relevant CFD unit are mounted on floating foundations. Please confirm all turbines of the relevant CfD Unit mounted on floating foundations. (*)

By selecting the response "Yes" the Applicant is making the declaration above.

Yes No

Application Checklist



1.3 Application (Generic) – Checklist



Applicant Checklist

Note: when submitting the application, the system will identify any invalid fields or mandatory fields that have not been completed. This will be flagged to the applicant before confirming submission. Please take the time to rectify these errors.

Have you completed the following*:

- Name, address and contact details of Applicant, and/or Agent (if non GB), and/or entity to enter into CfD Contract, and/or entity receiving notices under CfD Contract.
and
- Stated the CfD Unit project name and locational details for the site, including the provision of the CfD Unit Map.
and
- Entered a valid Initial installed capacity estimate in Megawatts (to 2 decimal places) *(Gross minus parasitic loads minus electrical losses)*
and
- Provided the applicable Project Target Dates: Target Commissioning Date (TCD) and Target Commissioning Window Start Date (TCWSD).
and
- All technology specific questions and relevant declarations.
and
- Any other information that LCCC require for the purpose of generating CfD contract, including selecting the type of CfD Contract and whether this will be standard or modified terms (if modified terms, must include date agreed with LCCC)
and
- Provided all required documentation for the Planning, Connection Agreement and Supply Chain Plan where relevant.

Note: this list is not exhaustive, and applicants will need to ensure you have completed the application in full.

Additional Technology Specific Questions



1.4 Application – Additional Technologies



The previous section covered the mandatory fields in the Application form for all technology types.

This section contains additional information required for certain technologies.

Select from the buttons below to find out more.

1.4.1
Advanced Conversion
Technologies (ACT)

1.4.2
Remote Island Wind (>5MW)
(RIW)

1.4.3
Offshore Wind

1.4.4
Floating Offshore Wind

1.4.1 Advanced Conversion Technologies (ACT)

Advanced Conversion Technologies (ACT) is defined as “a generating station which generates electricity by the use of Advanced Fuel (gas or liquid formed by Gasification or Pyrolysis of Biomass or Waste)”.

Requirements

- For Advanced Conversion Technology (ACT), the Applicant must demonstrate that the CfD Unit is expected to comply with the Physical Separation Requirement (PSR) by submission of a process flow diagram in the application form.
- Requiring the **synthesis** and **combustion** processes to be separated ensures clear distinction between ACT and less advanced processes that are closer to conventional boiler technologies.
- Please refer to the [ACT Guidance](#) documents which have been produced to support Applicants with the ACT requirements.
- Further details on the specific requirements for the process flow diagram can be found in the **Schedule 5 section of the AR5 Allocation Framework.**

Documents



[Compliance with the ACT Efficiency Standard criterion in the Contract for Difference scheme](#)

PDF, 322KB, 18 pages

This file may not be suitable for users of assistive technology. [Request an accessible format.](#)



[Compliance with the Physical Separation Requirement in the Contract for Difference scheme](#)

PDF, 208KB, 11 pages

This file may not be suitable for users of assistive technology. [Request an accessible format.](#)

Note: The ACT guidance was produced in Allocation Round 3 and is still valid for Allocation Round 5.

1.4.2 Remote Island Wind (>5MW)



Regulation 27A(3) of the Allocation Regulations, as amended by the Contracts for Difference (Miscellaneous Amendments) Regulations 2018, sets out the Remote Island Wind (RIW) Conditions to be met during assessment. In summary these are:

1. the CfD Unit generates electricity by the use of wind;
2. the CfD Unit is located on a Remote Island;
3. the CfD Unit is connected to the national Transmission System or to a Distribution System; and either

The CFD Unit is connected to the national Transmission System

The generation Circuit between the CFD Unit and the Main Interconnected Transmission System consists of not less than 50 km of Cabling, not less than 20 km of which is Subsea Cabling.

The CFD Unit is connected to a Distribution System

The electrical connection between its Grid Supply Point and the Main Interconnected Transmission System consists of not less than 50 km of Cabling, not less than 20 km of which is Subsea Cabling.

Note: RIW applications cannot be for a private wire only connection.

1.4.2 Remote Island Wind (>5MW)



- Template schematic diagrams for Remote Island Wind (RIW) CfD Units connecting to the national transmission system or to a distribution system, in the local government areas of **Comhairlean Eilean Siar**, **Orkney Islands Council**, and **Shetland Islands Council**, are available on the [GOV.UK landing page](#) for the Contracts for Difference Scheme, Allocation Round 5.
- Applicants should annotate the relevant diagram and submit it as part of their application to the Delivery Body to demonstrate that the project meets the condition in Regulation 27A(3)(d) of the Contracts for Difference (Allocation) Regulations 2014, as set out in Schedule 5 of the Allocation Framework.
- The eligibility requirements for RIW are geographically neutral and applications from any geographical location will be considered. RIW applicants from other island groups will find the templates useful in terms of the information that the schematic diagram must provide.

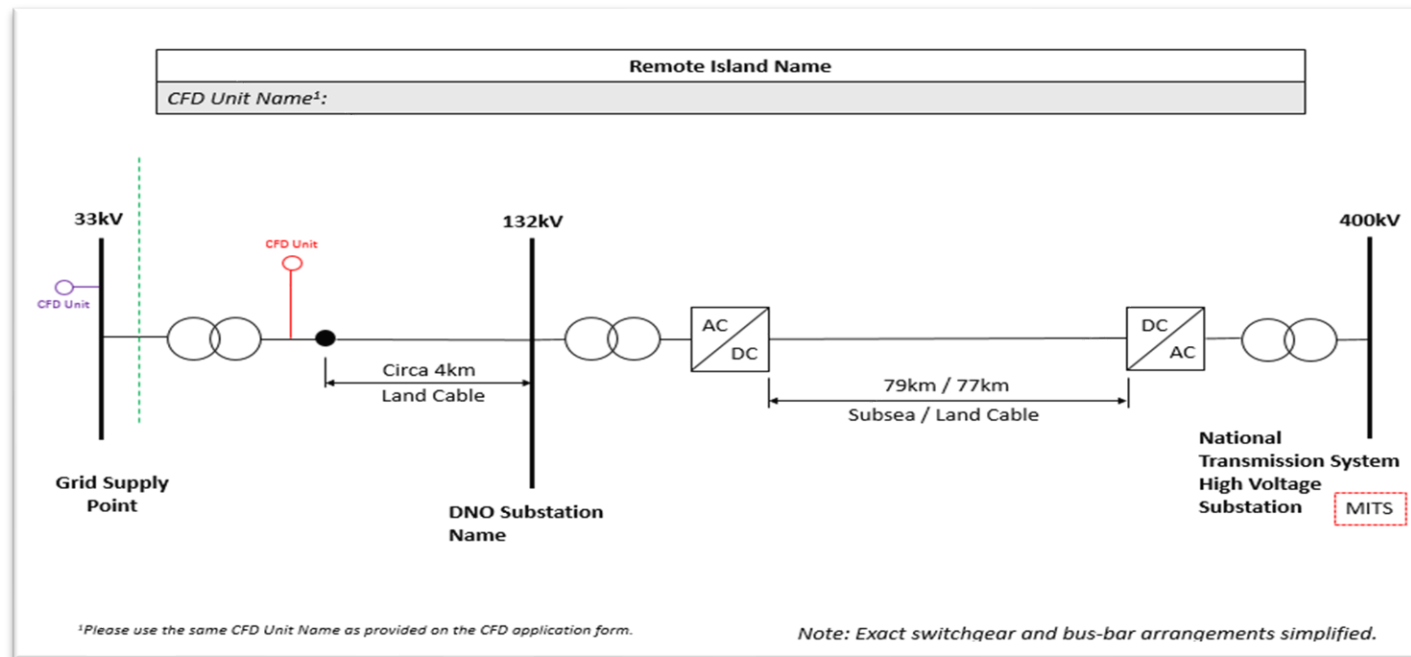

Schematic Diagram Example

This example shows how a project connecting to the Distribution network (*purple*) and Transmission network (*red*) would show their location schematically

1.4.2 Remote Island Wind checklist



Applicant Checklist

Have you completed the following*:

- Included a copy of your schematic diagram showing the cable distances and CfD Unit name as stated on your application form.
- and**
- Checked that your diagram provides the evidence for demonstrating that the condition in Regulation 27A(3) (d) will be met, as set out in Schedule 5 of the Allocation Framework.

1.4.3 Offshore Wind

Offshore Wind is the **only technology that can have more than 1 phase**. A maximum of three phases may be chosen. This needs to be confirmed at A10 on the General Tab of the CfD Application form.

A9: Technology Type (*)

Apart from Offshore Wind, technologies can only have a single phase and are therefore identified as Phase 1 in this application form

A10: Number of CfD Phases (*)

1
2
3

The **CfD Allocation Framework for AR5**, sets out the supplemental requirements for phased offshore wind. In summary these are:

- **If the CfD Unit is to be more than 1 phase then**, after all phases are completed, the CfD Unit will have a capacity of no greater than 1500 MW;
- **the first phase must represent at least 25% of the total capacity of the CfD Unit after all phases are completed;**
- the first phase is targeted to complete by a date no later than **31st March 2028** (subject to any changes to the Target Commissioning Date under Regulation 34 as a result of delays to the Allocation Process);
- the Target Commissioning Date (TCD) of the final phase is no later than 2 years after the TCD of the first phase.

1.4.4 Floating Offshore Wind

A floating offshore wind CfD unit is an offshore wind CfD unit that satisfies the floating offshore wind conditions (detailed below), pursuant to Regulation 27ZA, Contracts for Difference (Miscellaneous Amendments) Regulations 2021.

The applicant must demonstrate (in addition to the matter referred to in regulation 27(2))* that the relevant CfD unit is expected, by the target commissioning date, to satisfy the floating offshore wind conditions.

Floating Offshore Wind Conditions

- (a) the relevant CfD Unit is not a Phased Offshore Wind CfD Unit (or any other CfD Unit that is to be established or altered in phases of construction);
- (b) all turbines forming part of the relevant CfD Unit –
 - i. are mounted on floating foundations; and
 - ii. are situated in offshore waters of at least 45 metres depth (measured from the seabed to chart datum).

*27(2) The applicant must demonstrate that a lease or an agreement for lease has been granted by the Crown Estate in respect of the location of the relevant CFD unit.)

1.4.4 Floating Offshore Wind

Additional Documents

As part of their Application, Applicants must also provide:

1. information in the Application indicating where the applicable planning consent(s) state(s) that the consent granted is for floating foundations;
2. a colour-coded depth chart of the consented area with the project area boundary clearly marked, showing the different depths of the water; and
3. a declaration from the Applicant signed by a Director, that the relevant CfD Unit will meet all the Floating Offshore Wind conditions.
4. for Allocation Round 5 a statement made by the Secretary of State for the Department for Energy Security and Net Zero approving the Supply Chain Plan submitted in respect of that station must be provide. This is pursuant to Regulation 26(4) of The Contracts for Difference (Allocation) Regulations 2014 .

The Depth Chart must:

- Show the depths of the water, clearly delineated by colour;
- Show the boundary of the consented area, clearly labelled;
- Show the boundary of the project area, clearly labelled;
- Show turbine locations clearly marked and situated in areas of water of at least 45 metres depth.

1.5 Application Next Steps

Application Window Closure

- Once the Application Window has closed, the Qualification Assessment process begins ([see Section 2. Qualification](#)).
- The Delivery Body will then determine whether an Application qualifies to take part in the Allocation Process.

Qualification Assessment of Applications

- The Delivery Body will determine Qualification based on the information provided by the Applicant and in accordance with the requirements of the Eligibility Regulations, Allocation Regulations and the Round specific Allocation Framework.
- The Allocation Framework provides a list of the checks that the Delivery Body must carry out when assessing Applications. Applicants should refer to Schedule 5 of the Round specific Allocation Framework.

Qualification Assessment of Applications – Non-Qualification Outcome

- Failure to meet any of the Qualification Criteria and any additional information requirements will result in the Delivery Body making a non-qualification determination.
- The subsequent Non-Qualification Review and Qualification Appeal phases for Non-Qualifying Applicants **do not allow submission of additional evidence** that was not provided with the original Application.

Withdrawal of Applications

- An Application may be withdrawn by the Applicant up to and including the Application Window Closing Date, and, pursuant to Regulation 16(4), if an Auction is required and where a Notice of Auction has been issued by the Delivery Body, an Application may be withdrawn by the Applicant up to and including the Sealed Bid Submission Closing Date.
- Further information on the Withdrawals of Applications can be found in Rule 13 of the Allocation Framework.

2.0 Qualification



This section of the guidance outlines the requirements that Applicants need to adhere to in order to meet the Qualification criteria. It should be used in conjunction with Section 1. Application.

Select from the button opposite to find out more:

2.1 Key Qualification
Criteria

2.1 Key Qualification Criteria



The key Qualification criteria of the Application can be seen below. Click on the relevant icons to find out more.

Connection Agreements
(covered in the Application Section)

Planning Decision Notice
(covered in the Application Section)

2.1.1 Supply Chain Approval
Certificate if $\geq 300\text{MW}$

2.1.2 Cross-Subsidy Declarations

2.1.3 Evidence of Incorporation

2.1.4 Target Commissioning Date
Window

Application Form General Requirements
(covered in the Application Section)

2.1.1 Supply Chain Approval



Projects of 300MW and above, **or if the CfD Unit Technology is Floating Offshore Wind**, will need to provide a copy of their Supply Chain Approval Certificate, as provided by the Secretary of State. For further details, refer to [1.2 Supply Chain Plan](#).

Applicants

Provide a statement made by the Secretary of State under regulation 11 of the Electricity Market Reform (General) Regulations 2014 in relation to the relevant CFD unit.

ESO

Verify name on certificate vs. CfD Unit name and validity of approval certificate

2.1.2 Cross-Subsidy Declarations (1/2)



Regulation 14 (5), (9), (10) and (11) of the Contracts for Difference (Allocation) Regulations and the round specific Allocation Framework set out where an Applicant is excluded from applying for a CfD.

The exemptions are in relation to the particular application rather than the applicant. All Applicants shall be asked to make the following declarations in the application process:

Applicant Checklist for Cross Subsidy Declarations:

Can you confirm the following:

- The CfD Unit is not in receipt of Non-Fossil Fuels Obligation (NFFO)
and
- The CfD Unit is not in receipt of Scottish Renewables Obligation (SRO)
and
- The CfD Unit is not in receipt of a Capacity Market Agreement, or; not be pre-qualified for a Capacity Market Agreement, or; where an application for a Capacity Market Agreement has been made but not yet determined
and
- The CfD Unit is not in receipt of a CfD Agreement or Investment Contract
and
- The CfD Unit is not in receipt of Renewables Obligation (RO) subsidy
and
- The CfD Unit is not in receipt of an accreditation under the Renewable Heat Incentive Regulations 2011

2.1.2 Cross-Subsidy Declarations (2/2)



Applicants

Declarations that the CfD Unit is not in receipt of subsidies for CM, CfD, NFFO, SRO or RHI (if Energy from Waste with CHP).

Declaration that CfD Unit not in receipt /in receipt* of subsidies for RO (**If in receipt, confirm type of dual scheme plant*).

ESO

Check using locational parameters against public data whether CfD Unit already in CM, CfD, NFFO or SRO.

Ofgem confirm status in RO – if Ofgem are unsure then DB rely on declaration.

Rely on declaration for RHI.

2.1.3 Evidence of Incorporation

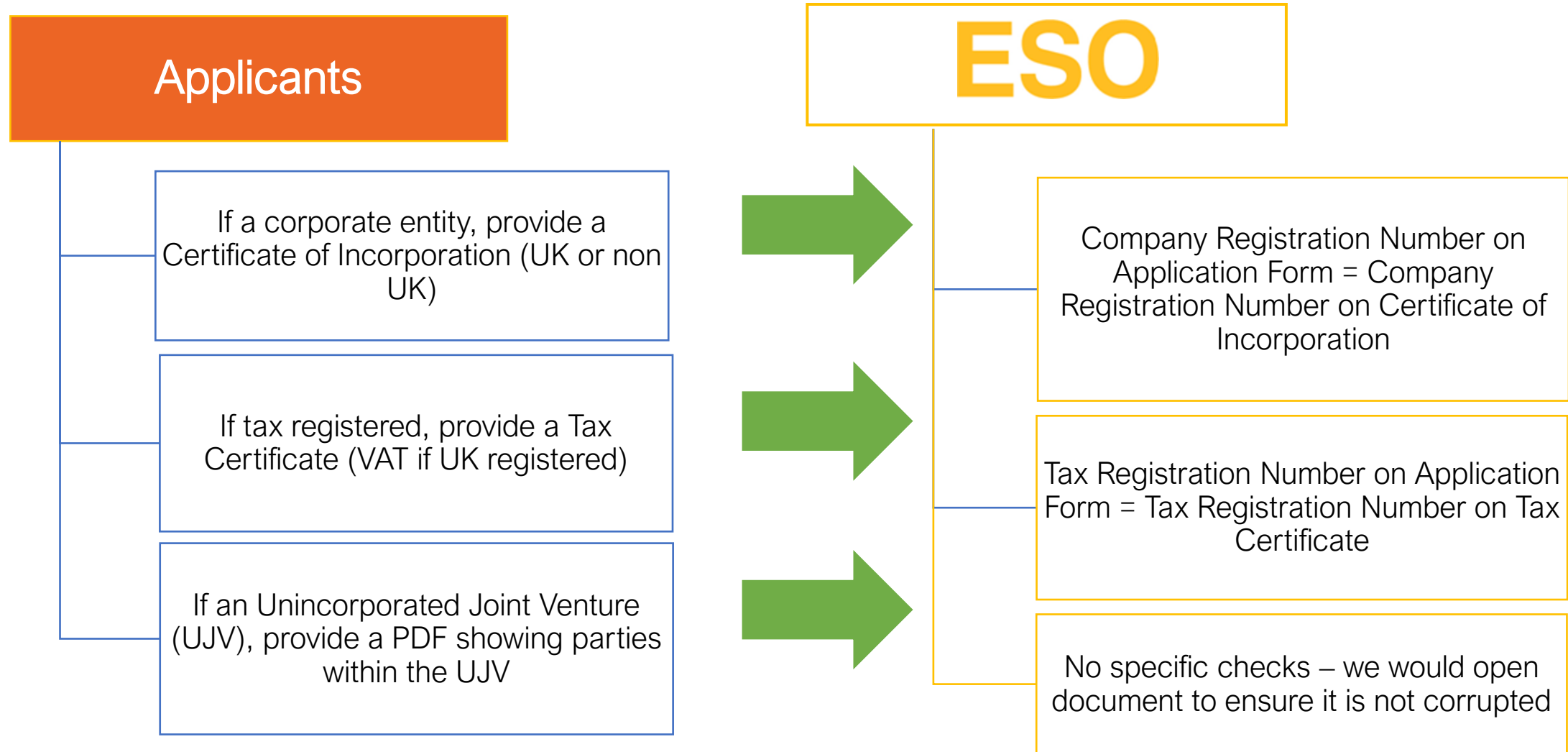

2.1.4 Target Date



Applicants

Provide a **Target Commissioning Date*** and a **Target Commissioning Window Start Date**** as part of CfD Application

* The earliest date that the Target Commissioning Date can fall is the first day of the first Delivery Year, and the latest date that the Target Commissioning Date can fall is the last day of the final Delivery Year.

** the earliest date that the Target Commissioning Window Start Date can fall is such that the final day of the Target Commissioning Window falls on the first day of the applicable Delivery Year.

The Target Commissioning Window End Date and Delivery Year is auto-populated based on the TCWSD.

ESO

The System prevents the Applicant from submitting an Application where:

The Target Commissioning Date is outside the Target Commissioning Window, and;

The Target Commission Date is before the first day of the first Delivery Year or beyond the last day of the final Delivery Year, and;

the Target Commissioning Window Start Date falls such that the final day of the Target Commissioning Window is before the first day of the applicable Delivery Year.

The Target Dates rules have exceptions for secondary phases of Phased Offshore Wind CFD Unit.

Please refer to Rule 4. Supplemental Requirements of the AF for more information on Phased Offshore Wind CfD Units.

3.0 Reviews



Non-Qualifying Applicants may give notice ('Review Notice') to the Delivery Body to request a Review of their Non-Qualification Determination where the Applicant believes that the Delivery Body has incorrectly applied the Rules.

Select from the buttons opposite to find out more:

3.1 Review process
overview

3.2 Review
requirements

3.1 Non-Qualification Review Process



- 1 Applicant**
 - Submit a Review Notice within 5 Working Days after the date of the Determination Notice
 - Cover only those areas subject to the Non-Qualification Determination
 - No new evidence can be submitted but original evidence can be clarified

Must issue a Non-Qualification Review Notice to the Applicant within 10 Working Days of the date on which the Review Notice is received.

- 2 Delivery Body**
 - Notify all Stakeholders that a Review process is in progress.

- 3 Outcome**
 - Non-Qualification Review Notice sent to Applicant either overturns or upholds the original decision and provides reasons for the Determination
 - If the original decision is upheld, then the Applicant can raise a Qualification Appeal to Ofgem. See the next section for guidance on how to raise a Qualification Appeal ([4. Appeals](#))

3.2 Non-qualification Review Requirements



Pursuant to Regulation 20, a Review Notice must contain:

- A concise statement which identifies the relevant part of the non-qualification determination in dispute and sets out the facts on which the Applicant relies
- A summary of the ground(s) for disputing the non-qualification determination
- A succinct presentation of the arguments supporting each of the grounds for dispute
- A schedule listing the documents submitted with the review notice
- No new documentary evidence can be submitted but the Applicant can clarify original evidence

4.0 Appeals

If a Non-qualification decision is upheld after Review, then the Applicant can raise an Appeal to Ofgem.

The Applicant must also notify the Delivery Body of their Appeal.

Select from the buttons opposite to find out more:

4.1 Appeals process

4.2 Pending (Allocation during Appeals)

 
Appeals guidance

4.1 Appeals Process



Appeal to Authority	Applicant	Submission of Appeal to Ofgem and a copy to the Delivery Body
		Up to 5 Working Days from receipt of Non-qualification Review Notice to submit an appeal to Ofgem
	Ofgem	The Authority must determine a qualification appeal as soon as practicable
		Allocation may proceed if there is a delay in receiving an Authority decision (see 4.2 Pending)
	Delivery Body	The Delivery Body may reply to a qualification appeal where it receives notice of an appeal from Ofgem
		Notification to stakeholders that there are Appeals in progress
		Delivery Body updates Appeals Register once CfD Notifications have been issued
	Outcome	Ofgem can overturn or uphold the original decision and provide reasons for the Determination
Authority gives notice to the applicant and Delivery Body, stating its determination and the date of the determination.		
Appeal to High Court	Applicant	28 calendar days to appeal to High Court or Court of Session in Scotland, where Ofgem upholds the Delivery Body's decision
	High Court	High Court could ask Ofgem to reconsider their decision or direct Delivery Body to reinstate as a Qualifying Applicant

4.2 Pending Application (Allocation during Appeals) <⏏>

Where, prior to the start of the Allocation Process, **The Authority** (Ofgem) has not notified the Delivery Body of the outcome of a Qualification Appeal, that Application shall be considered a **Pending Application**.

Pending Applicants and Allocation Round Notices

- Where specific notices are sent to **Qualifying** Applicants (e.g. an Auction Notice **stating the requirement for submission of Sealed Bids**), Applicants that are still awaiting an Appeals outcome (**Pending Applications**) will also be sent the same notices **with the same** requests and response dates, where relevant.

Pending Applicants and Sealed Bid Submission

- **Pending** Applicants that are still awaiting an Appeals outcome shall be permitted to submit Sealed Bids alongside other Qualifying Applicants. The Sealed Bid Submission process will be the same for Qualifying and Pending applicants. Please refer to the [Allocation Round 5 document area](#) on the CfD portal where the Sealed Bids guidance document can be found.

The Allocation Framework sets out several scenarios that govern how Pending Applications **(which become either Qualified or Non-Qualified Applications)** must be considered by the Delivery Body when determining if the applications can be **successful in the Auction**. Refer to the Round specific Allocation Framework Rule 23 for further details.

Contact Details and Feedback



Your feedback is important to us.

We are interested in your thoughts regarding this guidance document and how we can meet your customer requirements.

So that we can learn more, please remember to fill out the feedback survey.



The CfD Delivery Partners are:

ESO



Department for
Energy Security
& Net Zero

ofgem

LOW CARBON
CONTRACTS COMPANY

For support using this guide or for general enquiries please contact:

Phone: 01926 655 300

Email: emr.cfd@nationalgrideso.com



Faraday House, Warwick Technology Park,
Gallows Hill, Warwick, CV346DA

For further information on ESO publications
please visit: nationalgrideso.com